

MX-800

TWIN TURRET | TWIN SPINDLE

Fully intelligent complex turning-milling CNC lathe

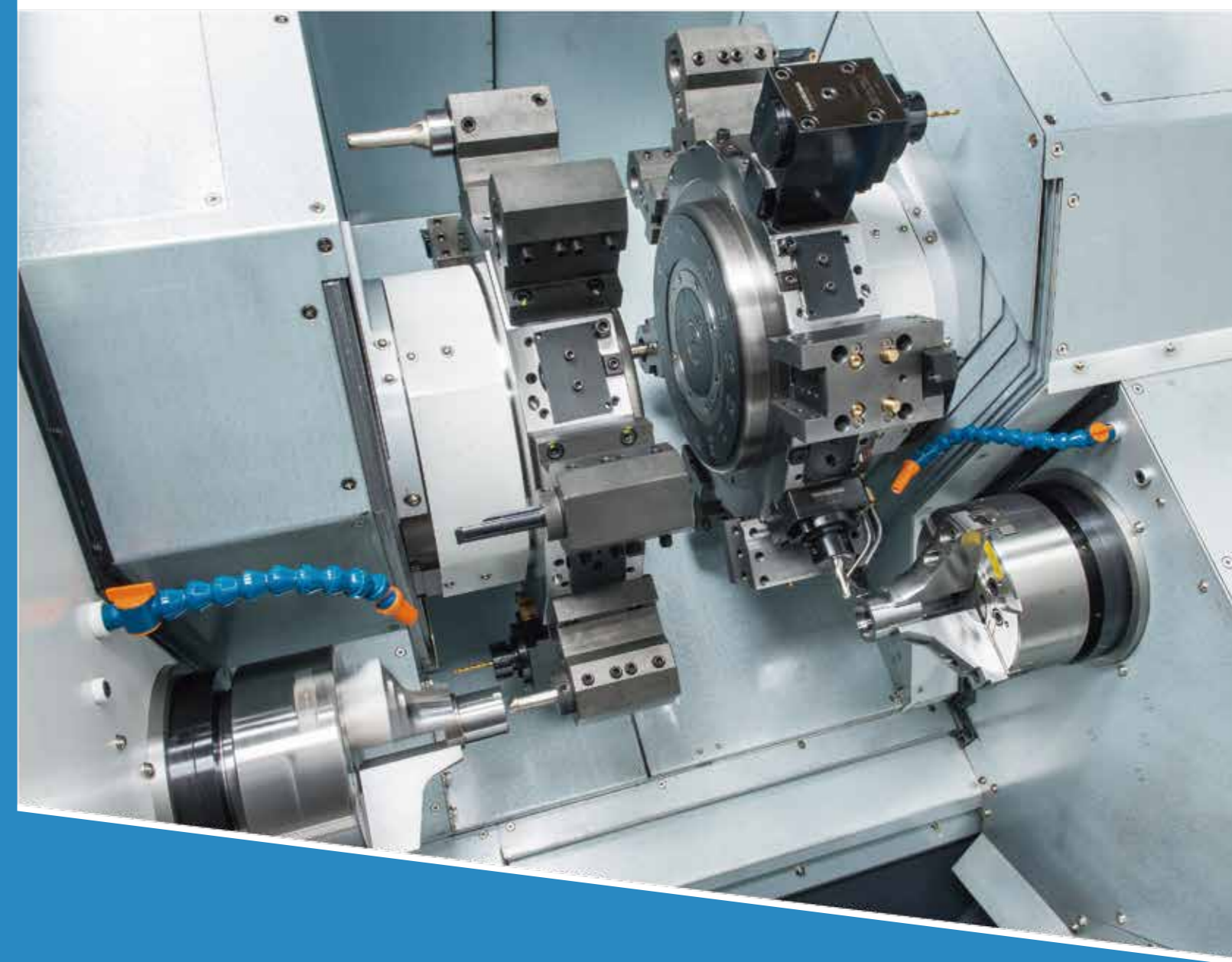

More

www.takisawa.com.tw

Taiwan TAKISAWA Technology Co., Ltd.

No.505, Sec. 3, Yenping Rd., Pingchen Dist.,
Taoyuan City 324, Taiwan.
TEL : +886-3-4643166 FAX : +886-3-4642614

No.89, Sec. 1, Meishi Rd., Yangmei Dist.,
Taoyuan City 326, Taiwan.
TEL : +886-3-4813119 FAX : +886-3-4813185
E-mail : callcenter@takisawa.com.tw

Shanghai TAKISAWA Mechatronics Ltd.

No.1568, Yuanguo Road, Anting Town, Jiading
District, Shanghai
TEL : +86-21-59562955 FAX : +86-21-59562956

TAKISAWA[®]
T A I W A N

Distributor



MX-800 Series



Specifications

- Max. turning length : 250mm
 - Max. turning dia. : 310mm
 - Max. bar work capacity : 52(65)mm
 - Bearing diameter : 100(110)mm
 - Spindle speed : 4000(3500)rpm
 - Spindle drive motor : 11/15(15/18.5)kW
 - Max. spindle torque : 188.2(242)N·m
- ※ Specifications are subject to change without notice.

Equipped with twin turrets and twin spindles this is a multi-tasking fully intelligent turning-milling CNC lathe for complex machining.

- Opposed left and right spindles and turrets allow independent machining by each spindle/turret system with interchange between the systems to reduce cycle times for highly complex machining.
- The compact working area with twin machining stations is designed for flexibility and fast component transfer for highly cost effective machining.
- Full roller guideways allow higher speeds that shorten cycle times to enhance capability for mass production.
- Increased distance between linear guideways on each axis improves rigidity and stability for highly accurate machining.
- The gantry loading option allows high speed mass production with minimal operator intervention.
- The MX-800 Series includes the following models:

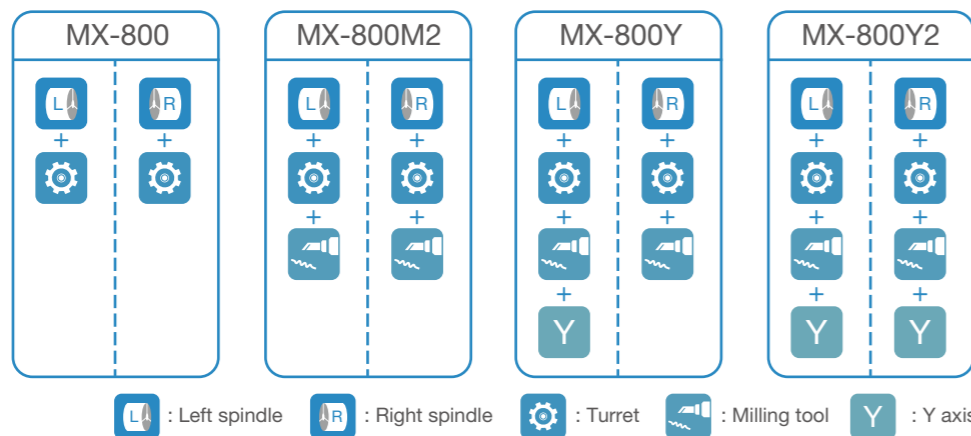

Spindle output diagram

Powered by FANUC MOTOR for high stability & high accuracy.

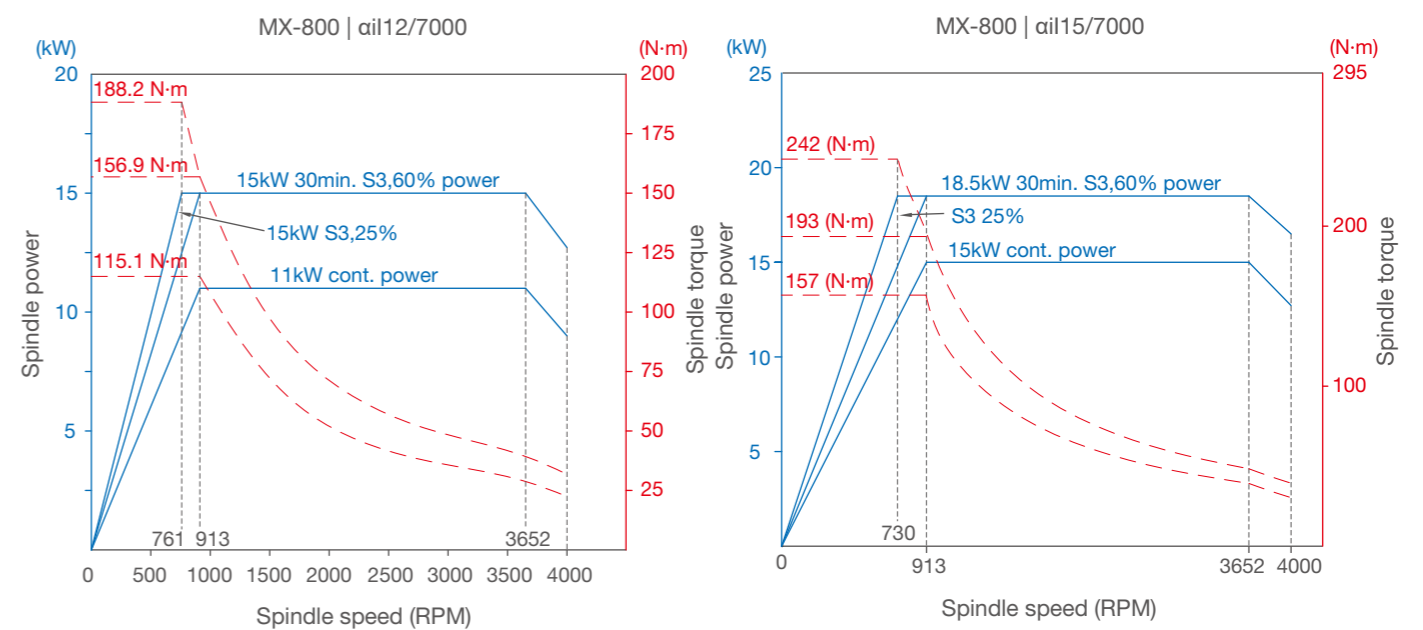



Increased distance between guide rails.
The extra heavy duty bed casting and its solid design structure ensures highly accurate and stable machining.

✓ Z axis guideway spacing is **25%** greater than already rigid older models.

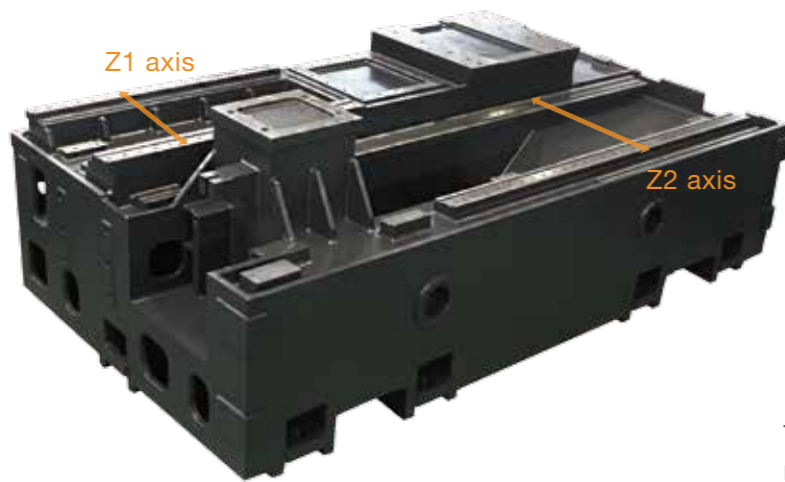

The latest grease lubrication system allows reductions of 80% in grease usage. The frequency of coolant replacement is also reduced.

Machine dimensions

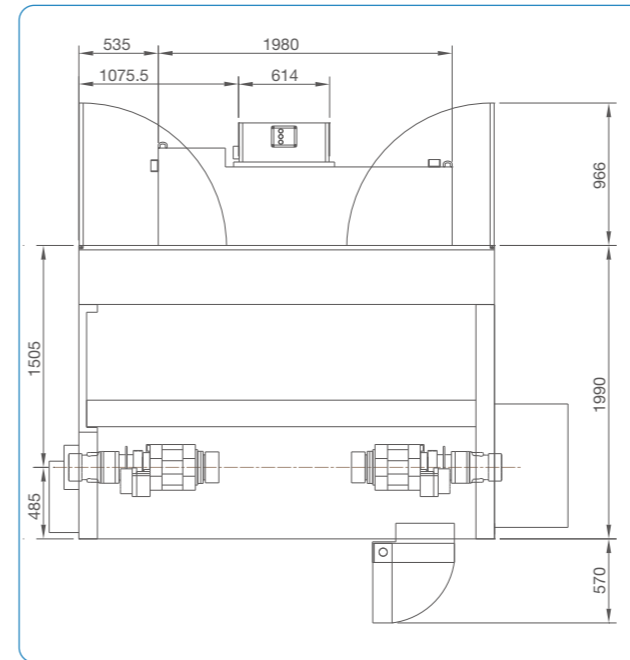

Top



The control panel is user friendly with swing arm and movable on a guide rail for convenient positioning.



Power chart for milling tool

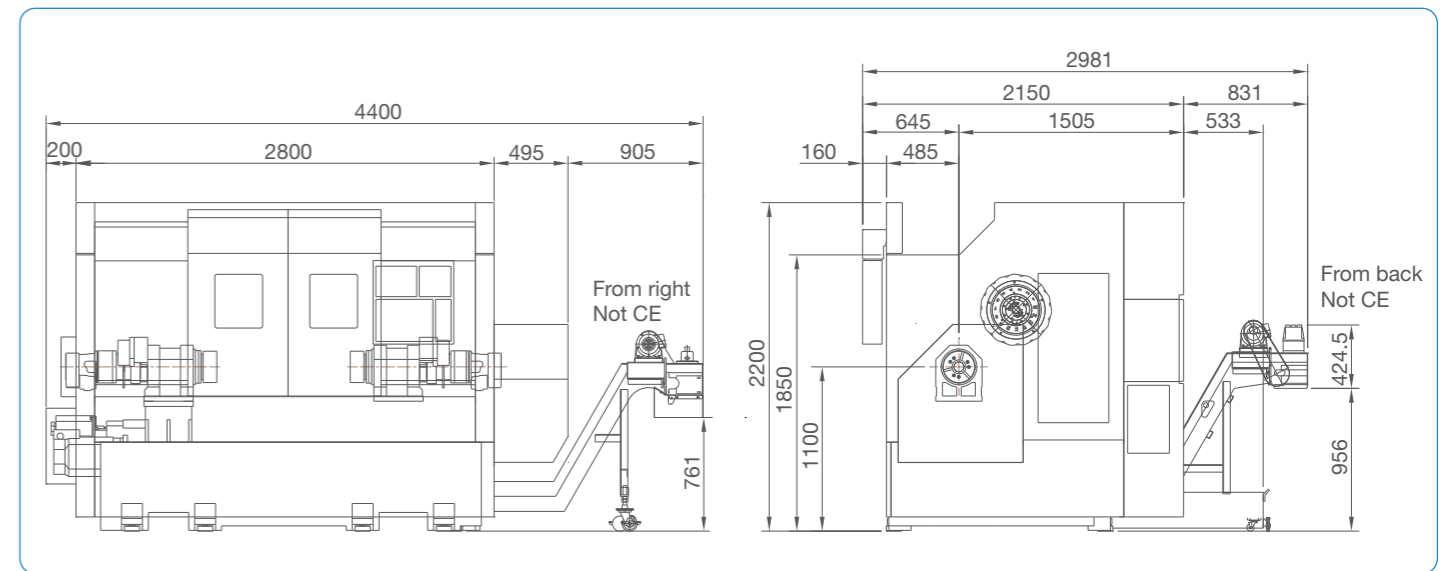
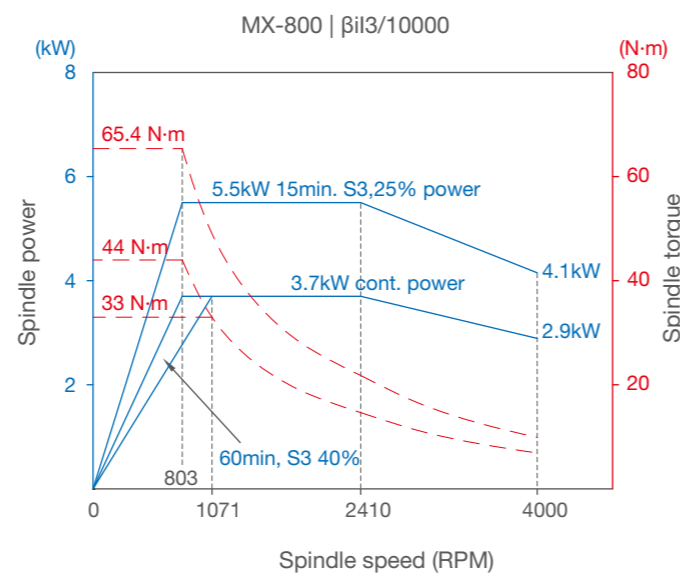

Front

Side

Unit : mm



Standard and optional accessories

An option to equip the MX-800 with a gantry loading system and parts conveyor radically shortens component handling times and coupled with the design of the twin turret/twin spindle system for the highest machining speeds, it provides the perfect solution for high-speed mass production.

■ Gantry
 ■ Hand type parts catcher
 ■ Bar feeder
 ■ Loader

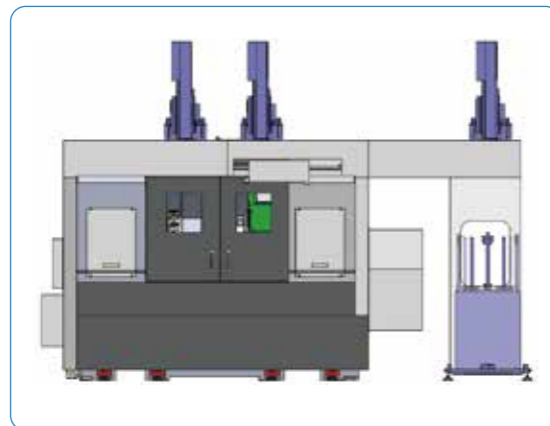

MX-800 Series + Gantry

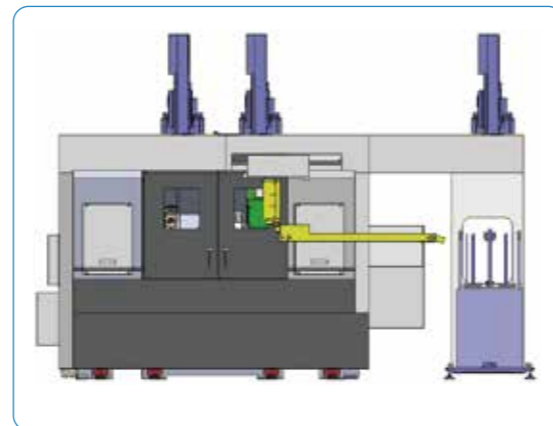

MX-800 Series + Gantry + Hand type parts catcher

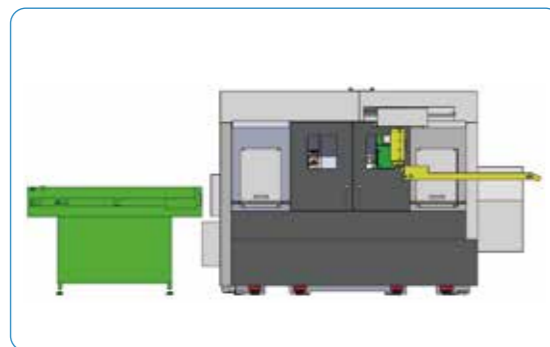

MX-800 Series + Hand type parts catcher + Bar feeder

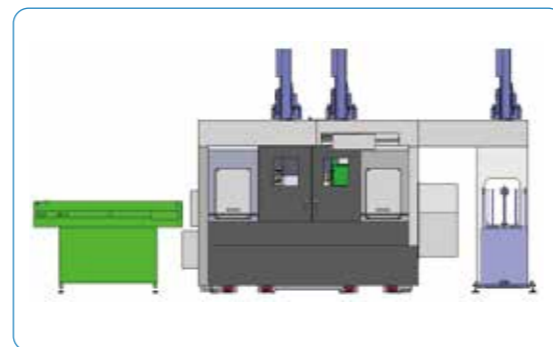

MX-800 Series + Gantry + Bar feeder

Standard accessories

1. Belt-driven spindle
2. Leveling pad
3. Tool wedge
4. LED working lamp
5. Tool box
6. Operation manual
7. Hydraulic chuck
8. Foot switch

Optional accessories

- | | |
|---|---------------------------|
| 1. servo live tool | 10. Parts catcher |
| 2. Bar feeder and interface | 11. Auto power off |
| 3. Manual tool setter | 12. Parts counter |
| 4. Automatic tool setter | 13. Collet chuck |
| 5. Spindle air blow | 14. Oil skimmer |
| 6. Gantry and loader | 15. Auto chip shield door |
| 7. Lifting jig | |
| 8. Internal parts catcher and conveyor | |
| 9. Right side/rear - in chip conveyor with cart | |

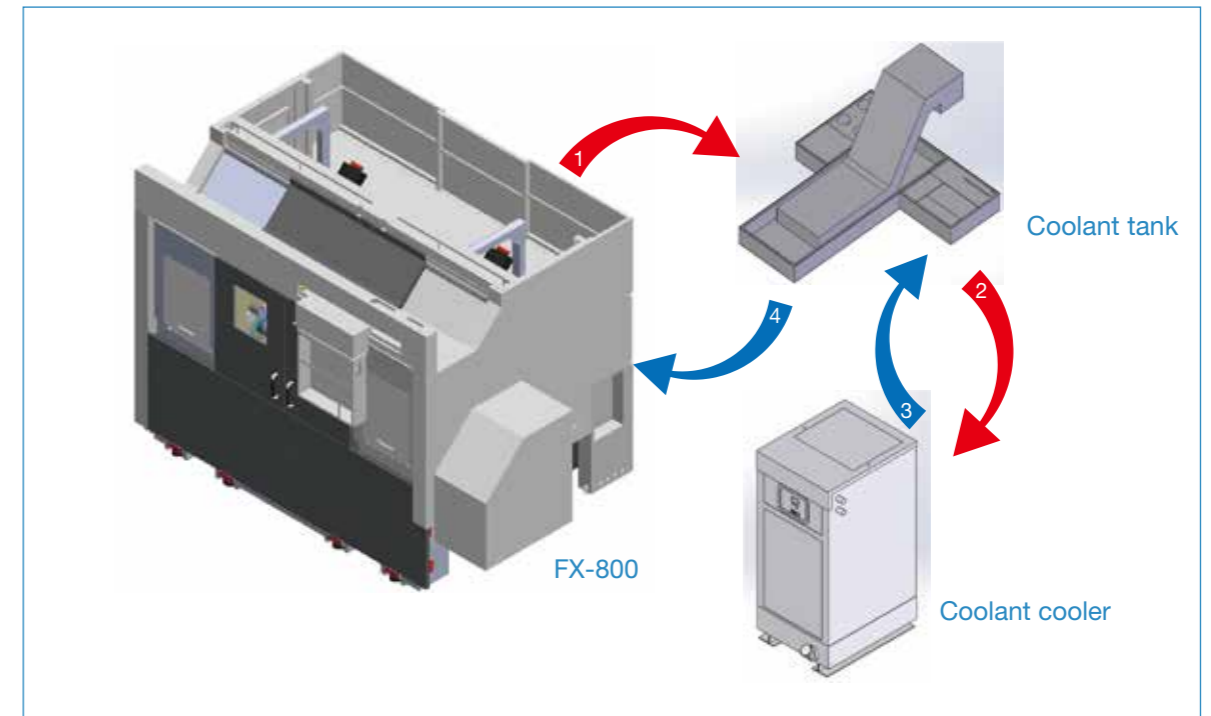

- Coolant Cooler Unit -

Coolant temperature affects workpiece accuracy, and for heavy cutting this option is recommended to reduce coolant temperature. The effectiveness of this unit is influenced by type and frequency of heavy cutting.

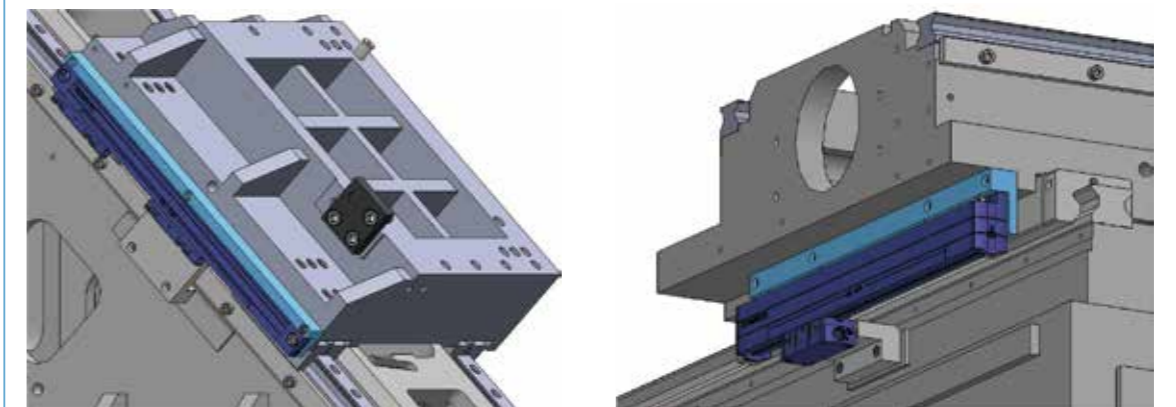

- Linear Scale (X and Z axis) - This option promotes high resolution and the highest machining accuracy.



- Tool Setter -

Use of either a manual or automatic tool setter speeds up tool setting and increases machining efficiency.



- The external measuring option & The internal measuring option -

This option ensures accuracy of machining and increased product quality by allowing compensation to ensure more accurate machining tolerances.





Working range | Interference diagram

MX-800

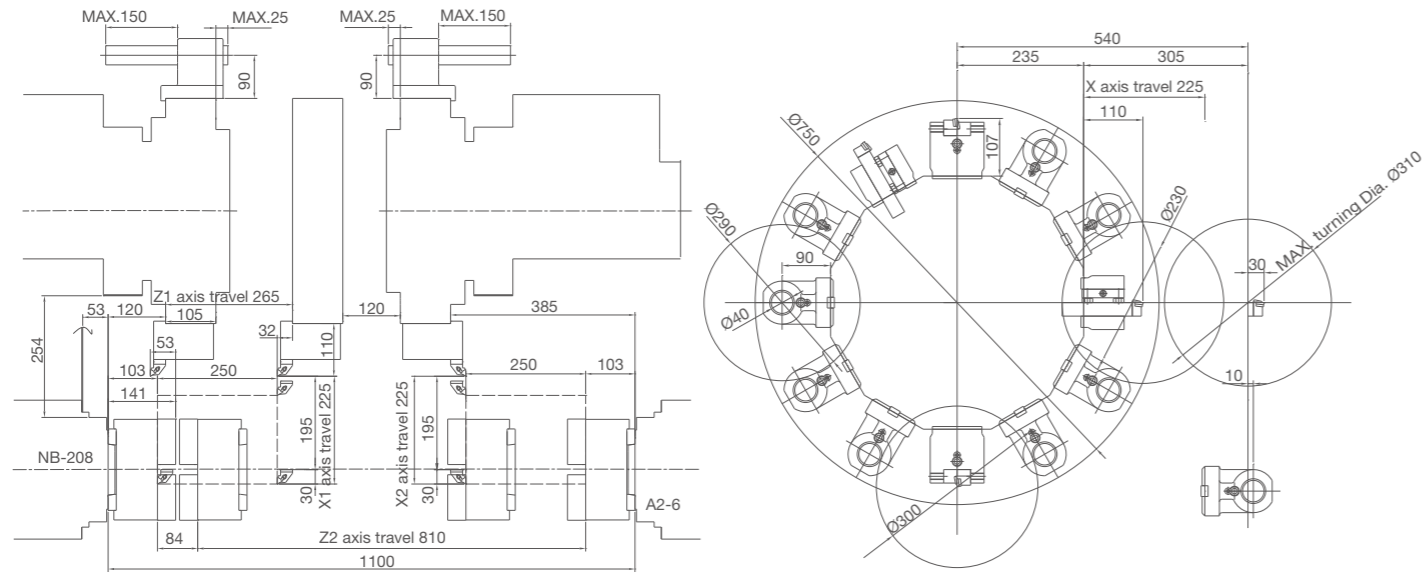

MX-800Y

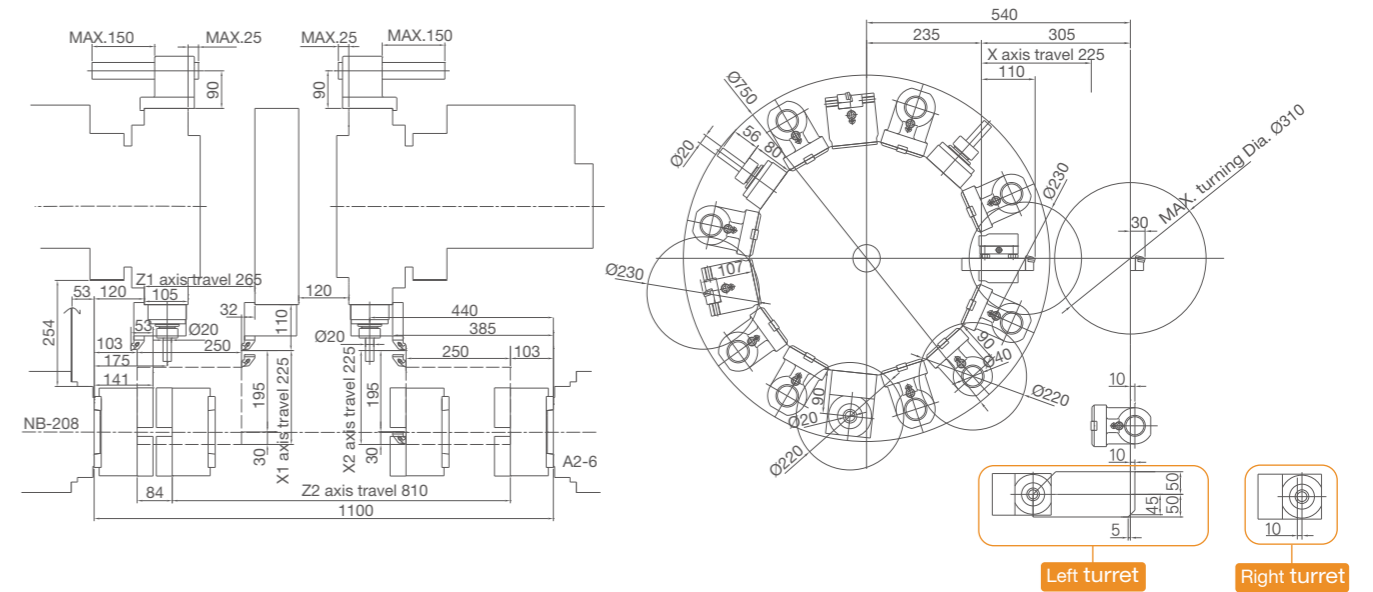

MX-800M2

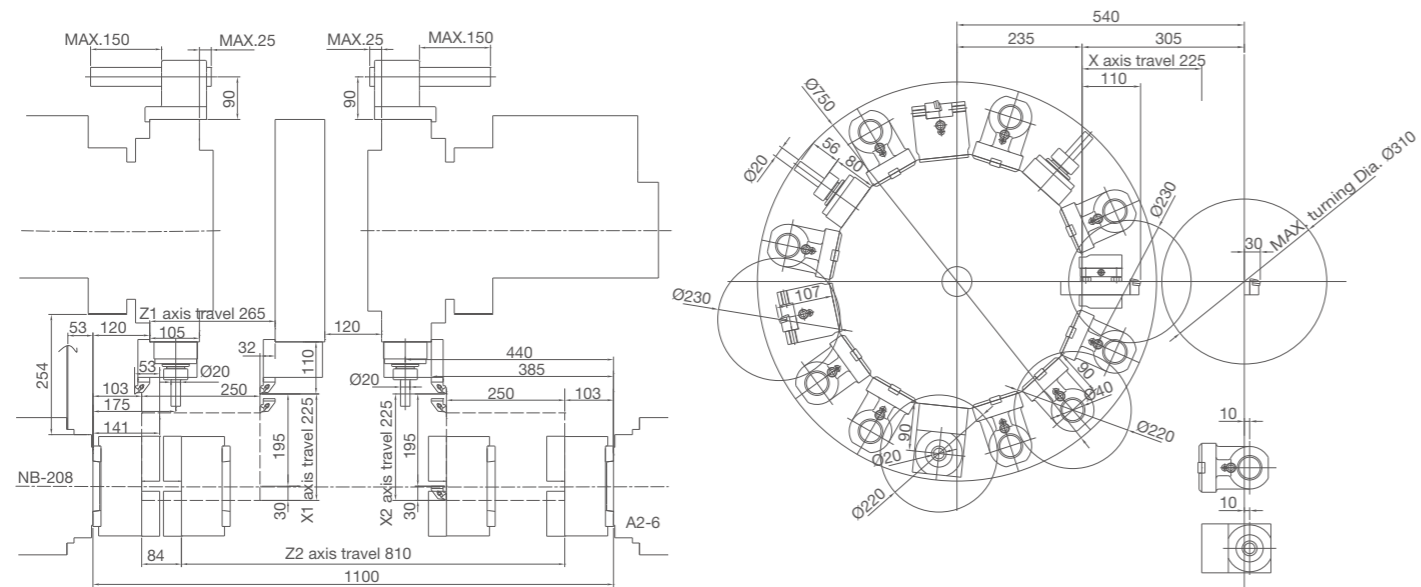

MX-800Y2

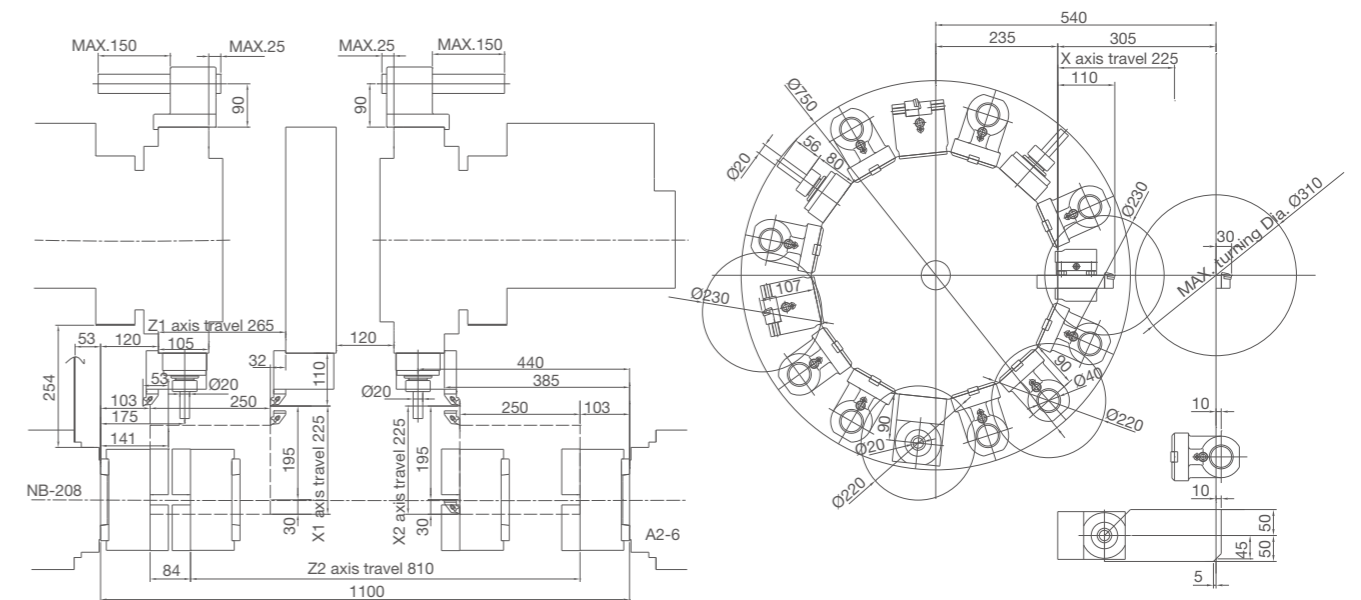

Tooling system

Specifications

MX-800

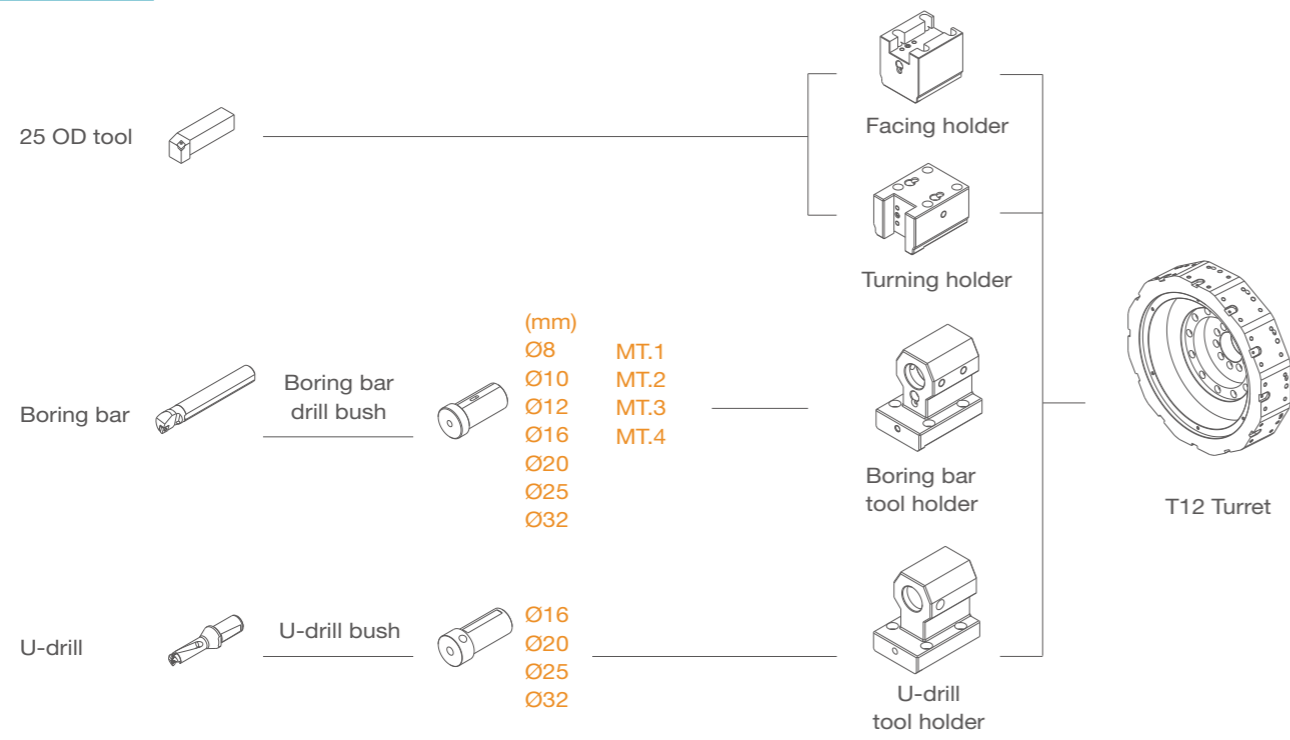

MX-800M2 / MX-800Y / MX-800Y2

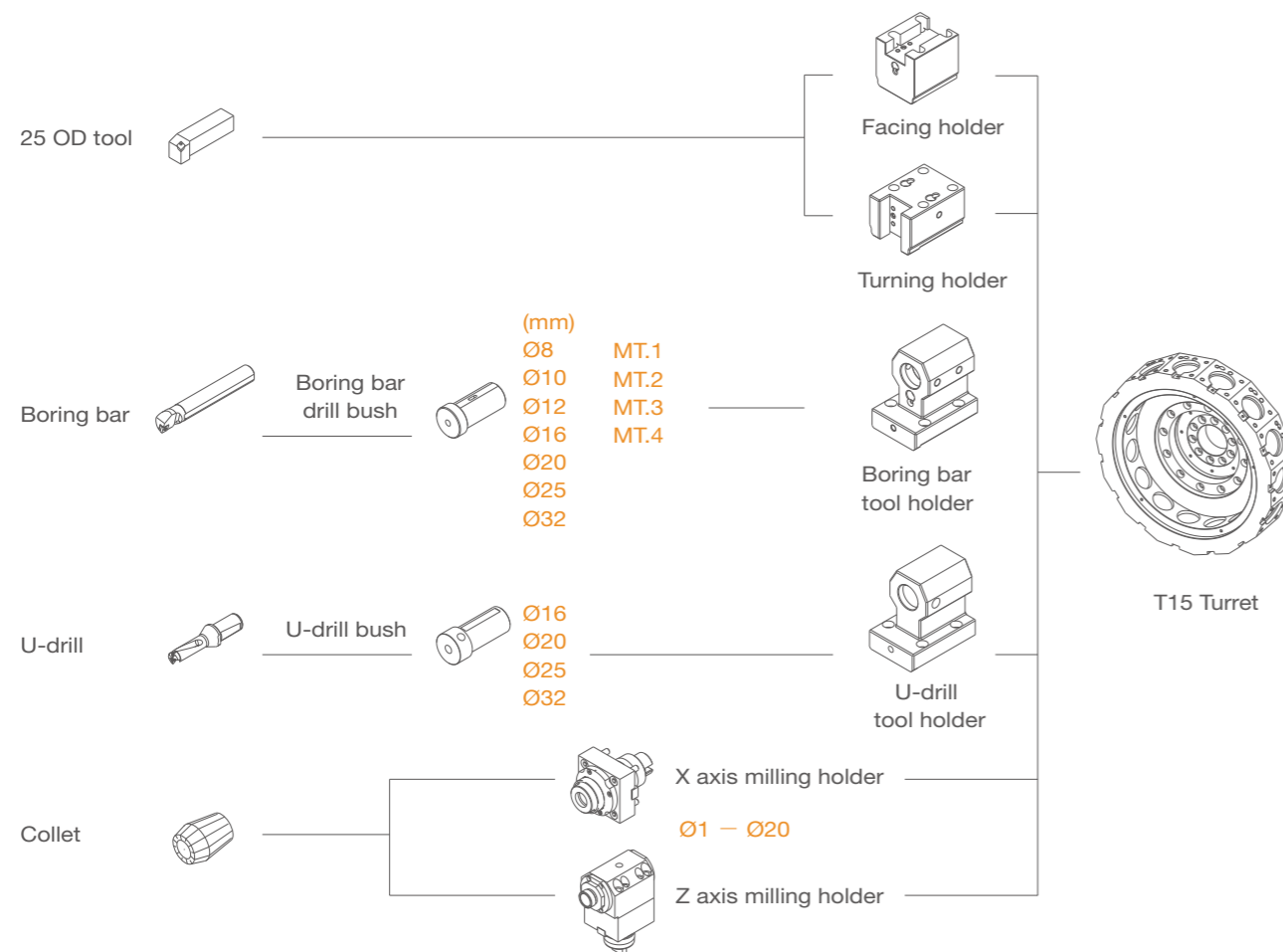

Remark1: () Option --- none

Item	Unit	MX-800	MX-800M2	MX-800Y	MX-800Y2
Capacity					
Standard turning diameter	mm		230		
Max. turning diameter	mm		310		
Max. turning length	mm		250		
Max. bar work capacity	mm		52 (65) / 52 (65)		
Distance between two spindle face	mm		Max.1100 / Min.290		
Spindle					
Spindle speed	rpm		4000 (3500)		
Chuck size			8"		
Spindle nose			A2-6		
Through hole diameter	mm		63 (76)		
Bearing diameter	mm		100 (110)		
Sub. spindle					
Spindle speed	rpm		4000 (3500)		
Chuck size			8"		
Spindle nose			A2-6		
Through hole diameter	mm		63 (76)		
Bearing diameter	mm		100 (110)		
Turret					
Number of turrets			2		
Number of tool stations		T12+T12		T15+T15	
Turning tool shank	mm		25		
Boring bar shank diameter	mm		40		
Milling speed	rpm	---	4000		
Milling shank diameter	mm	---	Ø1-Ø20		
Travel					
X1/X2 axes travel	mm		225		
Z1/Z2 axes travel	mm		265/810		
Y axis travel	mm	---	---	Y axis:±50	Y1/Y2 axes:±50
Feedrate					
X1/X2 axes rapid traverse rate	m/min		20		
Z1/Z2 axes rapid traverse rate	m/min		20(24)		
Y axis rapid traverse rate	m/min	---	---	Y axis:6	Y1/Y2 axes:6
Motor					
Spindle drive motor	kW		11 / 15 (15 / 18.5)		
Sub. spindle drive motor	kW		11 / 15 (15 / 18.5)		
Milling motor	kW	---	3.7/5.5		
Turret index motor	kW		1.2		
X1/X2 axes drive motor	kW		2.5/2.5		
Z1/Z2 axes drive motor	kW		2.5/2.5		
Y axis drive motor	kW	---	---	Y axis:2.5	Y1/Y2 axes:2.5
Machine size					
Height	mm		2200		
Width	mm		3495		
Depth	mm		2150		
Weight	Kg		8000		

※ Specifications are subject to change without notice.