

LX-2500 LX-3000 Series

L7 / L13 / L20 **CNC Turning Center**

/// **Taiwan TAKISAWA Technology Co., Ltd.**

Pingchen /
No. 505, Sec 3, Yenping Rd., Pingchen Dist.,
Taoyuan City, 32453, Taiwan
TEL: +886-3-4643166 FAX: +886-3-4642614

Yangmei /
No. 89, Sec. 1, Meishi Rd., Yangmei Dist.,
Taoyuan City, 32659, Taiwan
TEL.: +886-3-4813119 FAX: +886-3-4813185
E-mail: callcenter@takisawa.com.tw

/// **Takisawa Mechatronics (Zhejiang) Ltd.**

Zhejiang /
188 Baoqun East Road, Jiashan County,
Jiaxing City, Zhejiang Province, China
TEL: +86-573-89103672 FAX: +86-573-89103671

/// **TAKISAWA Tech Corp**

U.S.A /
15271 Fairfield Ranch Rd., Unit 130,
Chino Hills, CA 91709, U.S.A
TEL: +1-866-606-6143 / +1-909-308-0903
E-mail: joshua.huang@takisawatechcorp.com

/// **TAKISAWA Tech Asia Co.,Ltd.**

Thailand /
18/31 M.7, Bangchalong, Bangphi,
Samutprakan, 10540, Thailand
TEL: +66-20465900 FAX: +66-20465901
E-mail: nuttapong@takisawa.com

/// **www.takisawa.com.tw**

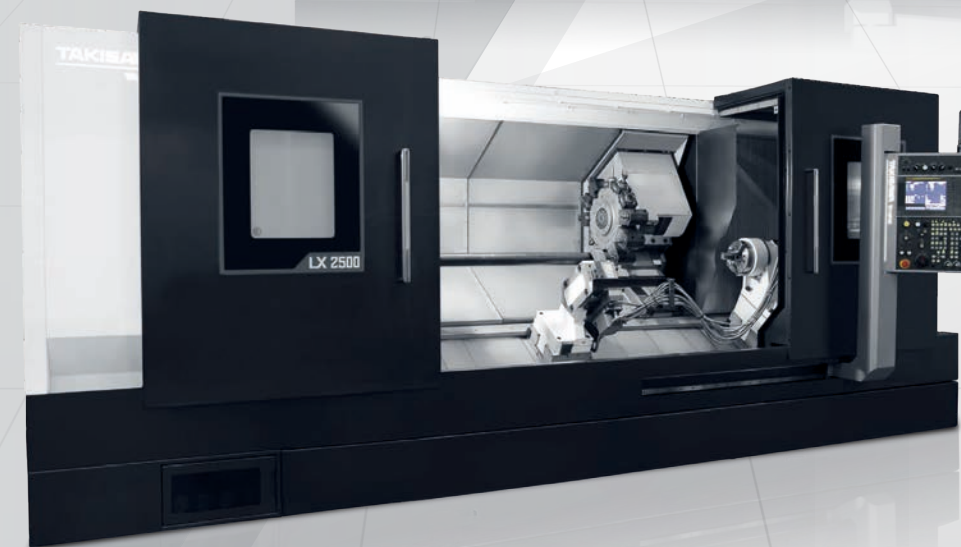
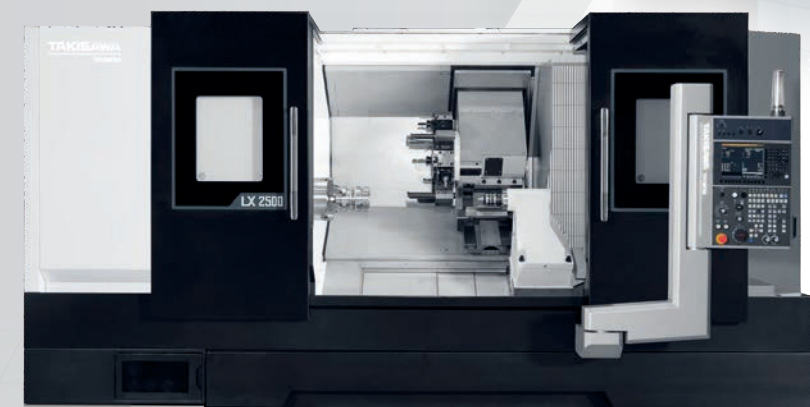

LX-2500 LX-3000 series

The LX-2500, LX-3000 series is a new generation high precision turning center developed for highly precise machining through its extremely strong and rigid structure and a design to counter the impact of thermal shock.

The range is available in a variety of spindle, turret and tailstock configurations with high precision peripheral options.

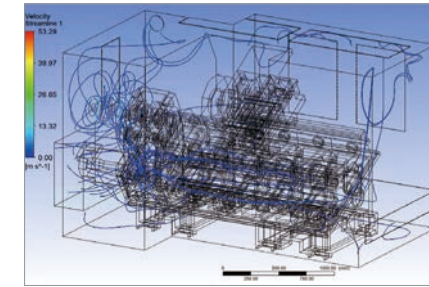

Structural design based on thermal flow field analysis maintains the highest precision at different ambient temperatures.

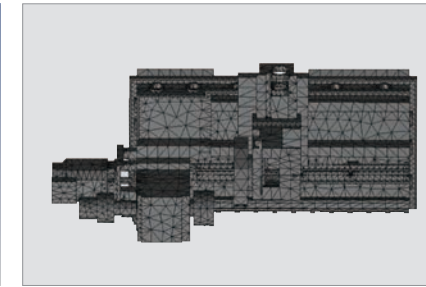

Structural design and thermal displacement analysis to enhance static stiffness and limit thermal displacement improves rigidity by more than 30% over previous designs.

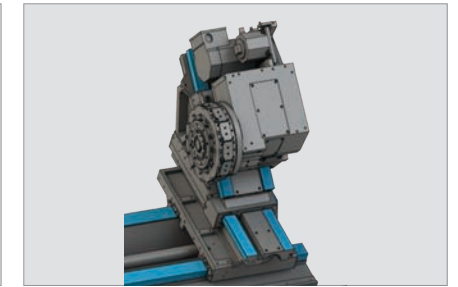

The X/Y/Z - Axis Box Ways design ensures dynamic rigidity and absorbs vibration to maintain accuracy with heavy cutting.

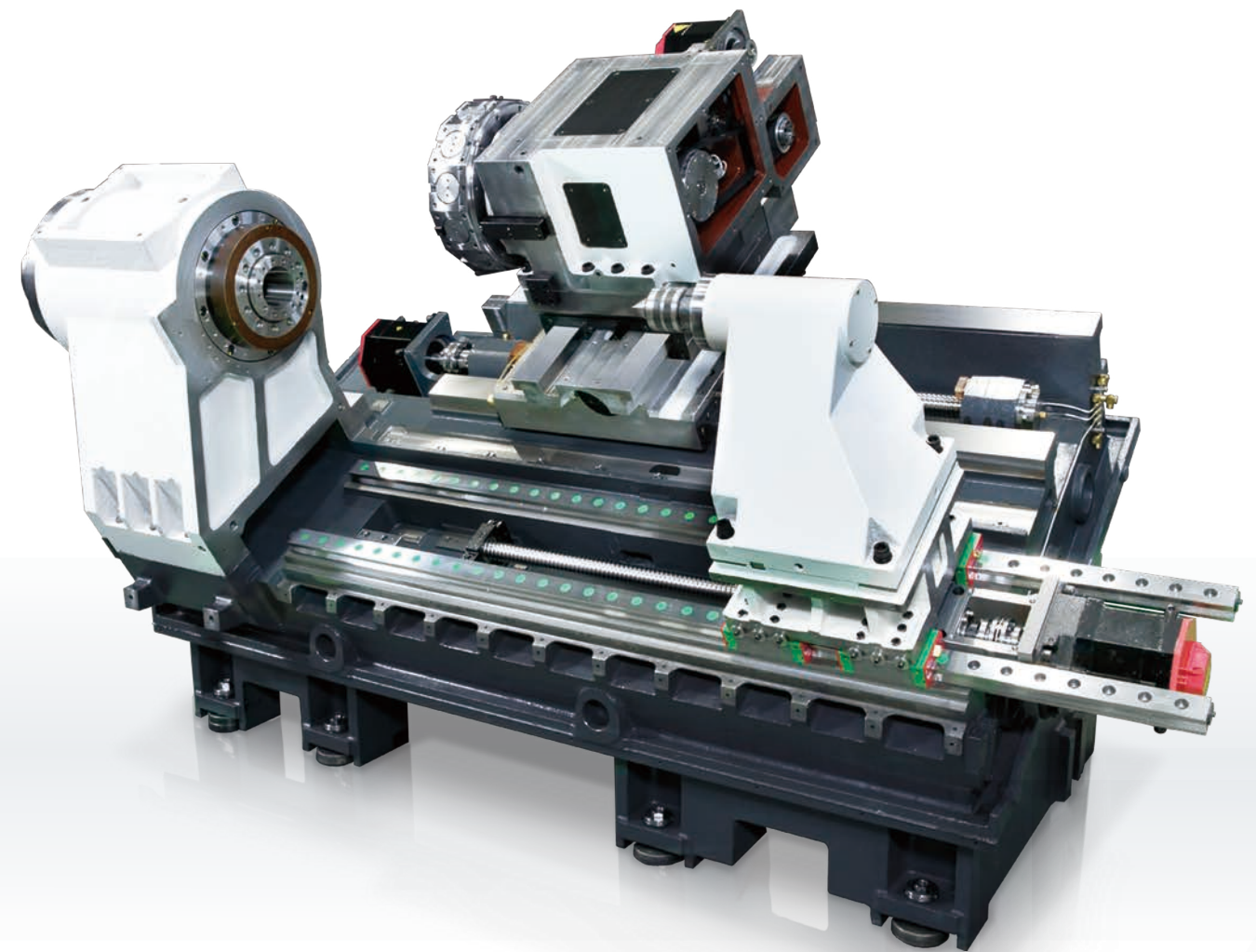

01 Workpiece Size

	LX-2500	LX-2500M	LX-2500Y	LX-3000	LX-3000M	LX-3000Y	
Max. Turning Diameter	470	420	420	470	420	420	mm
Max. Turning Length	732/1367/2117	698/1333/2083	698/1333/2083	701/1336/2086	667/1302/2052	667/1302/2052	mm
Max. Bar Work Capacity Diameter	81	81	81	90	90	90	mm

L7/L13/L20

02 Specification Options

	LX-2500	LX-2500M	LX-2500Y	LX-3000	LX-3000M	LX-3000Y
Built-In Motor Spindle	●	●	●	●	●	●
GearBox Spindle	◎	◎	◎	◎	◎	◎
P Motor Spindle	◎	◎	◎	◎	◎	◎
T10 Turning Turret	◎	-	-	◎	-	-
T12 Turning Turret	●	-	-	●	-	-
T12 Milling Turret	-	●	●	-	●	●
Y-Axis	-	-	●	-	-	●
Servo Tailstock	●	●	●	●	●	●

● Standard ◎ Optional - Nope

03 Travel & Rapid Traverse

	LX-2500	LX-2500M	LX-2500Y	LX-3000	LX-3000M	LX-3000Y	
X-Axis Travel	275	275	275	275	275	275	mm
X-Axis Rapid Traverse	24	24	24	24	24	24	m/min
Z-Axis Travel	815/1450/2200	815/1450/2200	815/1450/2200	815/1450/2200	815/1450/2200	815/1450/2200	mm
Z-Axis Rapid Traverse	30	30	30	30	30	30	m/min
Y-Axis Travel	-	-	±50	-	-	±50	mm
Y-Axis Rapid Traverse	-	-	10	-	-	10	m/min
B-Axis Travel	730/1365/2115	730/1365/2115	730/1365/2115	730/1365/2115	730/1365/2115	730/1365/2115	mm
B-Axis Rapid Traverse	20	20	20	20	20	20	m/min

L7/L13/L20

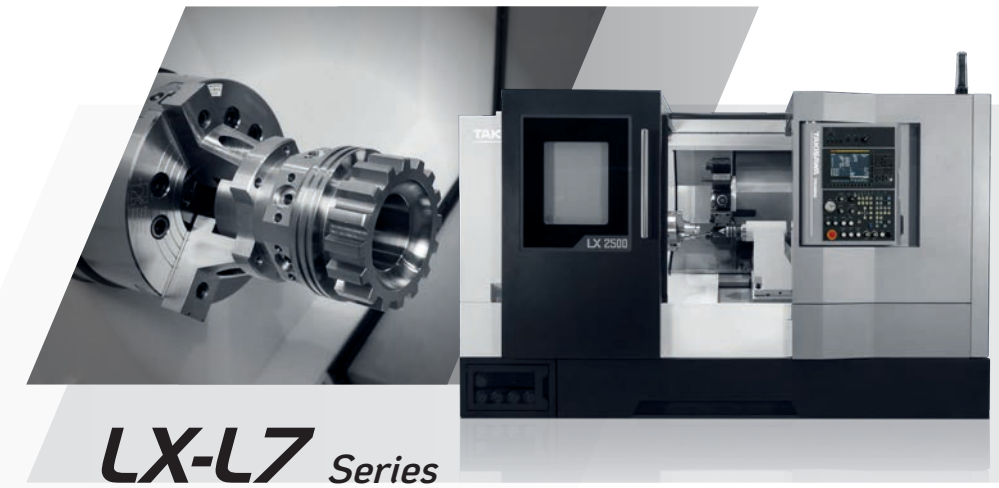

LX-L7 Series

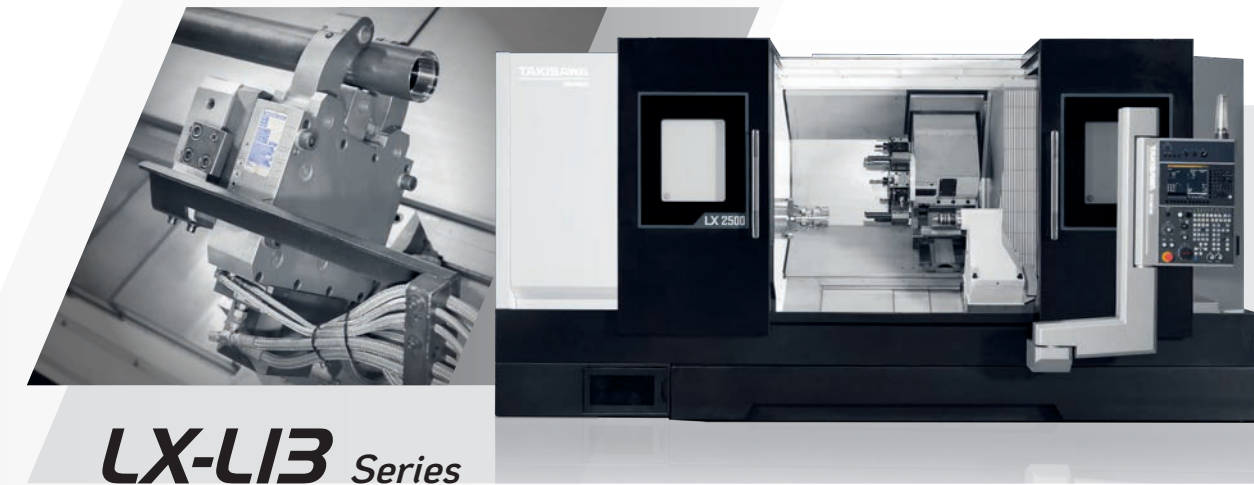

LX-L13 Series

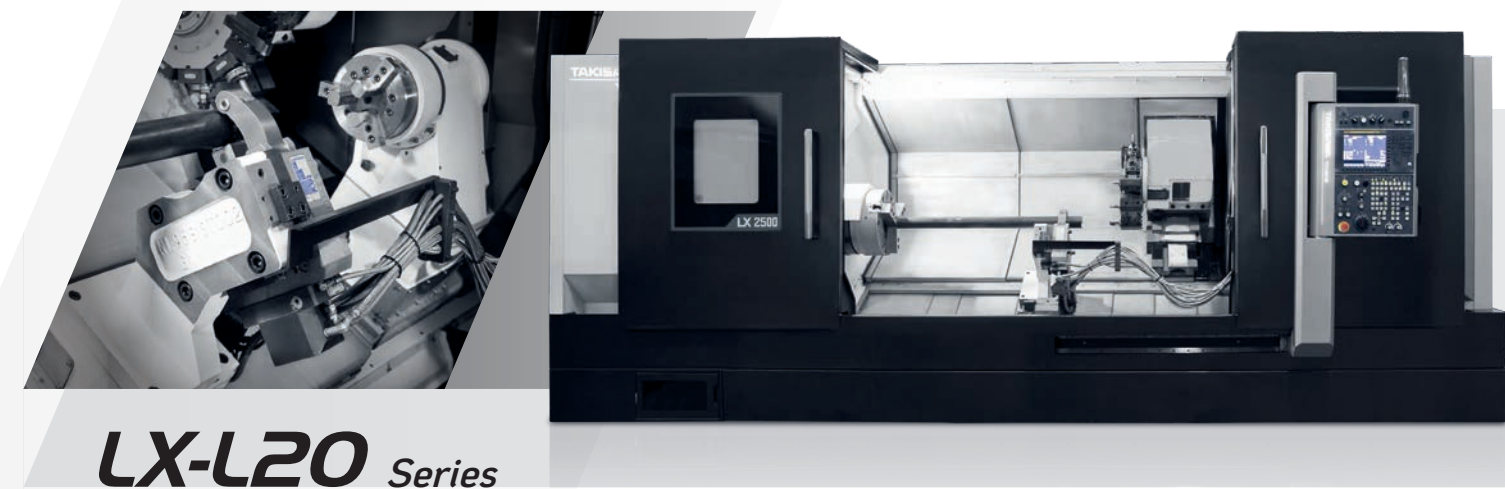

LX-L20 Series

Spindle

The spindle is made in house to ensure highest quality and reliability. There are three types: Built-in spindle motor; Gear Box headstock and P motor headstock. These alternatives allow choices for precision, torque or cost effectiveness.

The LX series uses the traditional TAIKISAWA Gear Box spindle design which has been proven through many generations of highly reliable products.

Motors, through-hole size, spindle speed ratios, nose etc can be amended when possible following a customised needs assessment.

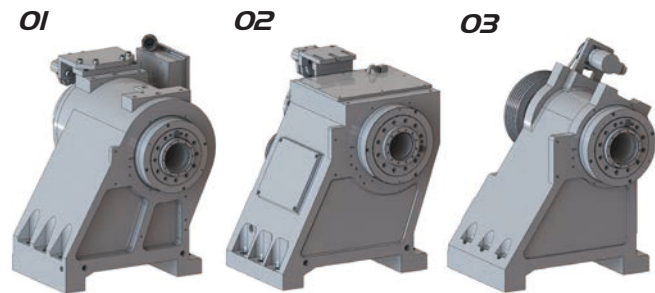
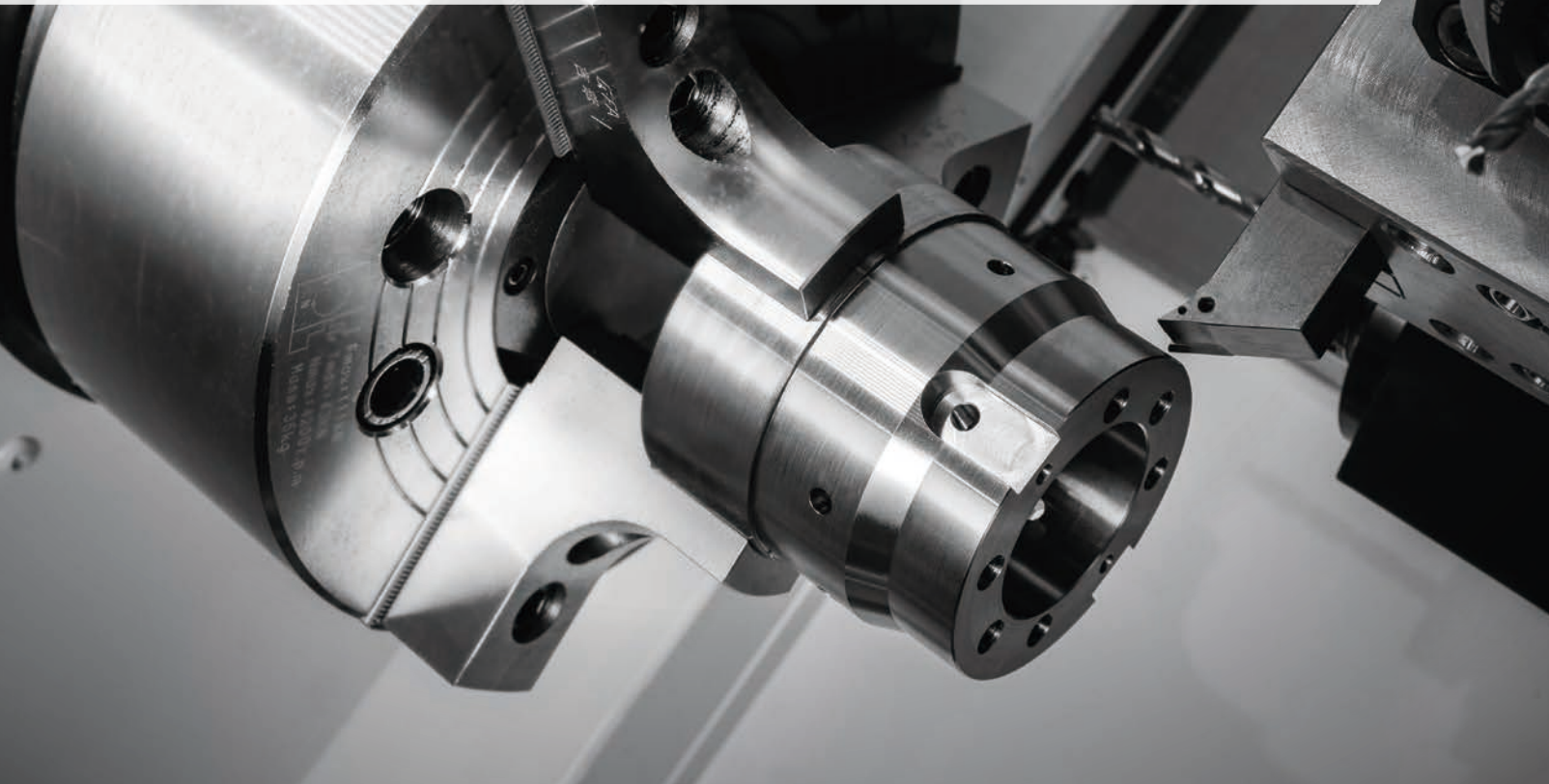
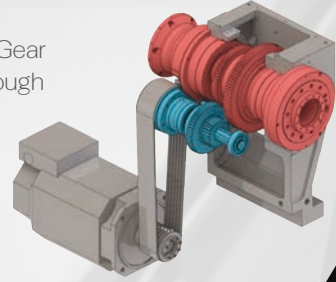

01 Built-In Motor

With minimal vibration and fast response throughout the whole speed range the Built-In motor is the best choice for the highest precision.

02 Gear Box

Switching between low and high speed settings allows large depth of cut and high torque.

03 P Motor

This is the most economical and highly reliable spindle option.

LX-2500	Built-In Motor	GearBox	P Motor
Spindle Nose	A2-8	A2-8	A2-8
Spindle Speed	3500	3500	3500 (3000) rpm
Through Hole Diameter	91	86	91 mm
Bearing Inside Diameter	120	120	120 mm
Motor Output	22 / 15	18.5 / 15 (22 / 18.5)	18.5 / 15 kW
Max. Torque	433	738 (877)	392 (456) N-m

LX-3000	Built-In Motor	GearBox	P Motor
Spindle Nose	A2-8	A2-8	A2-8
Spindle Speed	2800	2800	2800 rpm
Through Hole Diameter	102	102	102 mm
Bearing Inside Diameter	140	140	140 mm
Motor Output	22 / 15	22 / 18.5	18.5 / 15 kW
Max. Torque	618	877	392 N-m

() Optional

Spindle Output Diagram

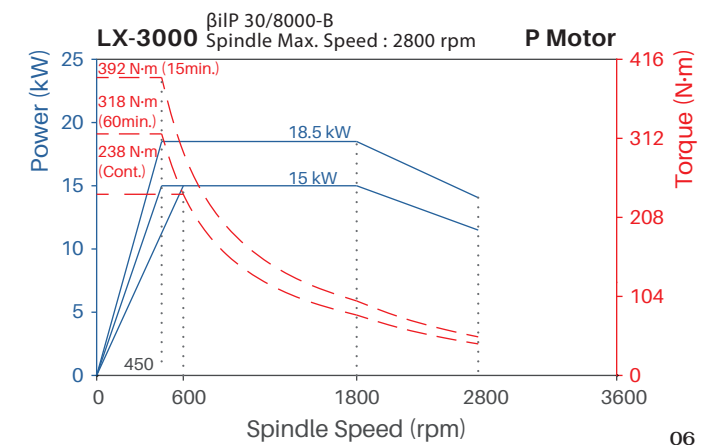
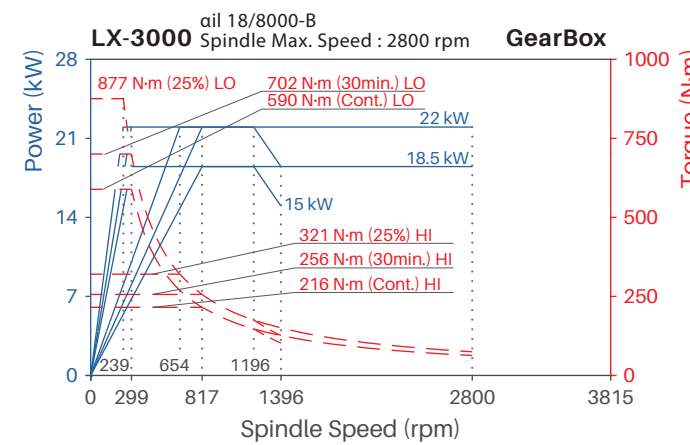
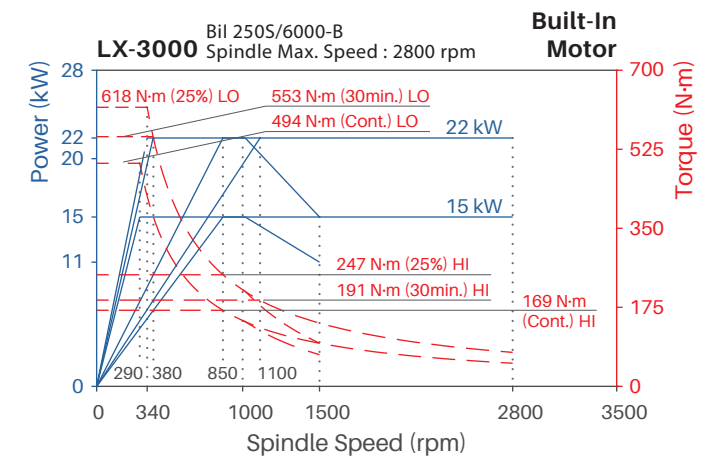
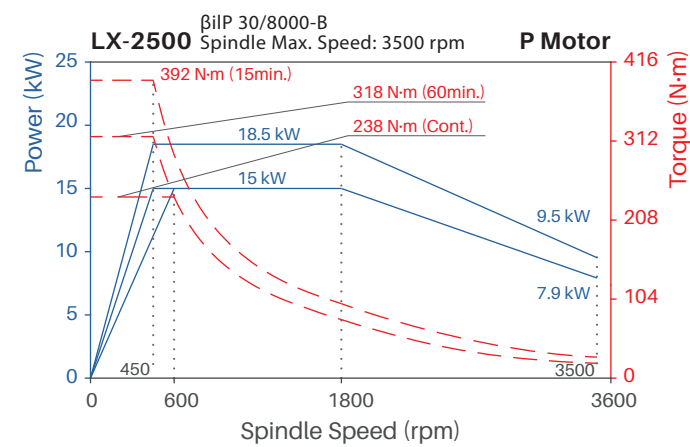
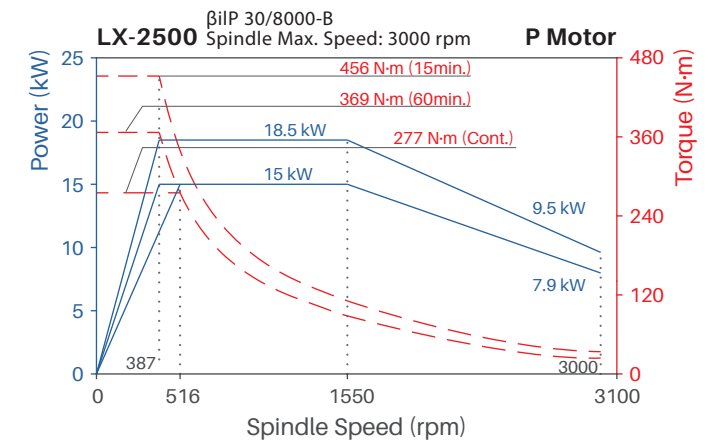
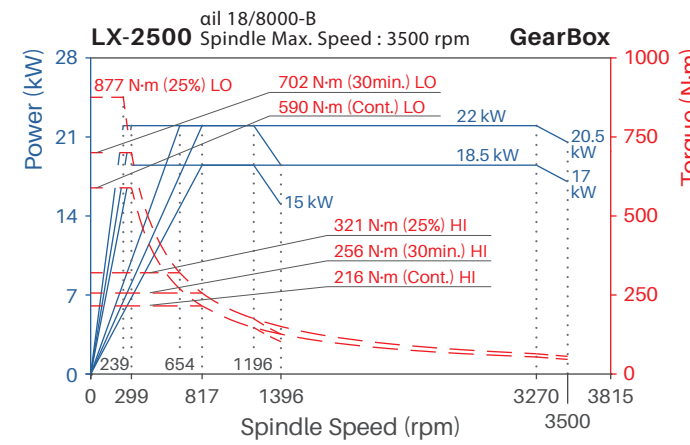
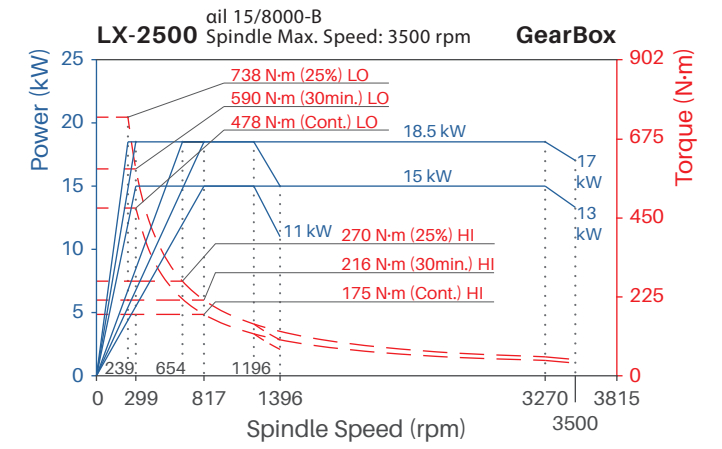
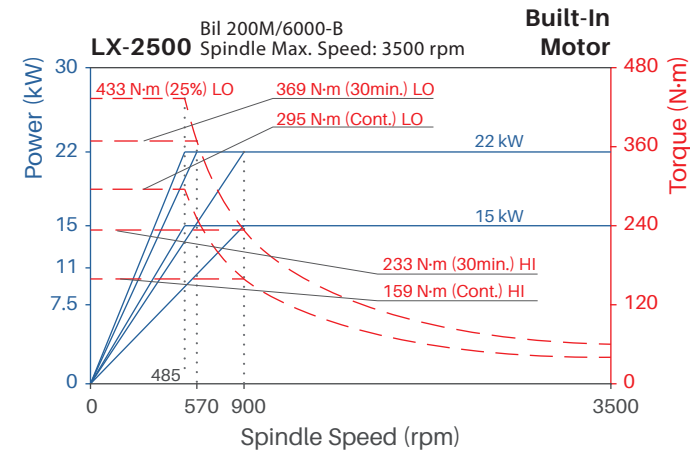

Turret

The T12 Milling Turret is a tested in house design that enables combined machining such as milling, drilling and tapping in addition to conventional turning. This allows complex and highly accurate machining in a single cycle for mass production of parts.

We can provide a customised needs assessment for special needs regarding numbers of tools, tool holders, milling cutters etc.

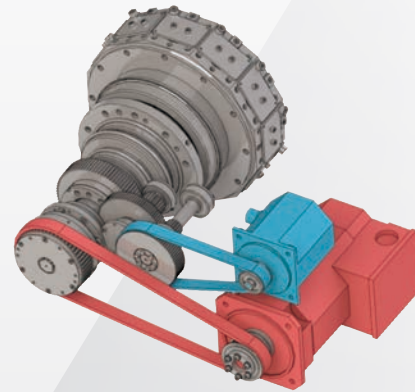

— The milling motor is driven by a spindle motor and the tool changer is driven by a servo motor.

Spindle Output Diagram

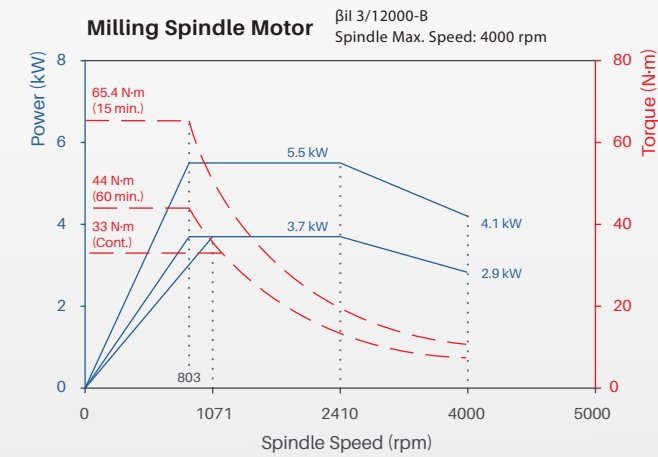

Turret Structure

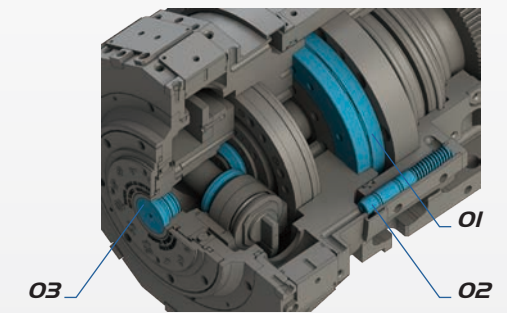

- 01** Curvic coupling OD 210 mm performs high rigidity and accuracy.
- 02** Ready for 70 bar hi-pressure coolant.
- 03** Easy to grease up.

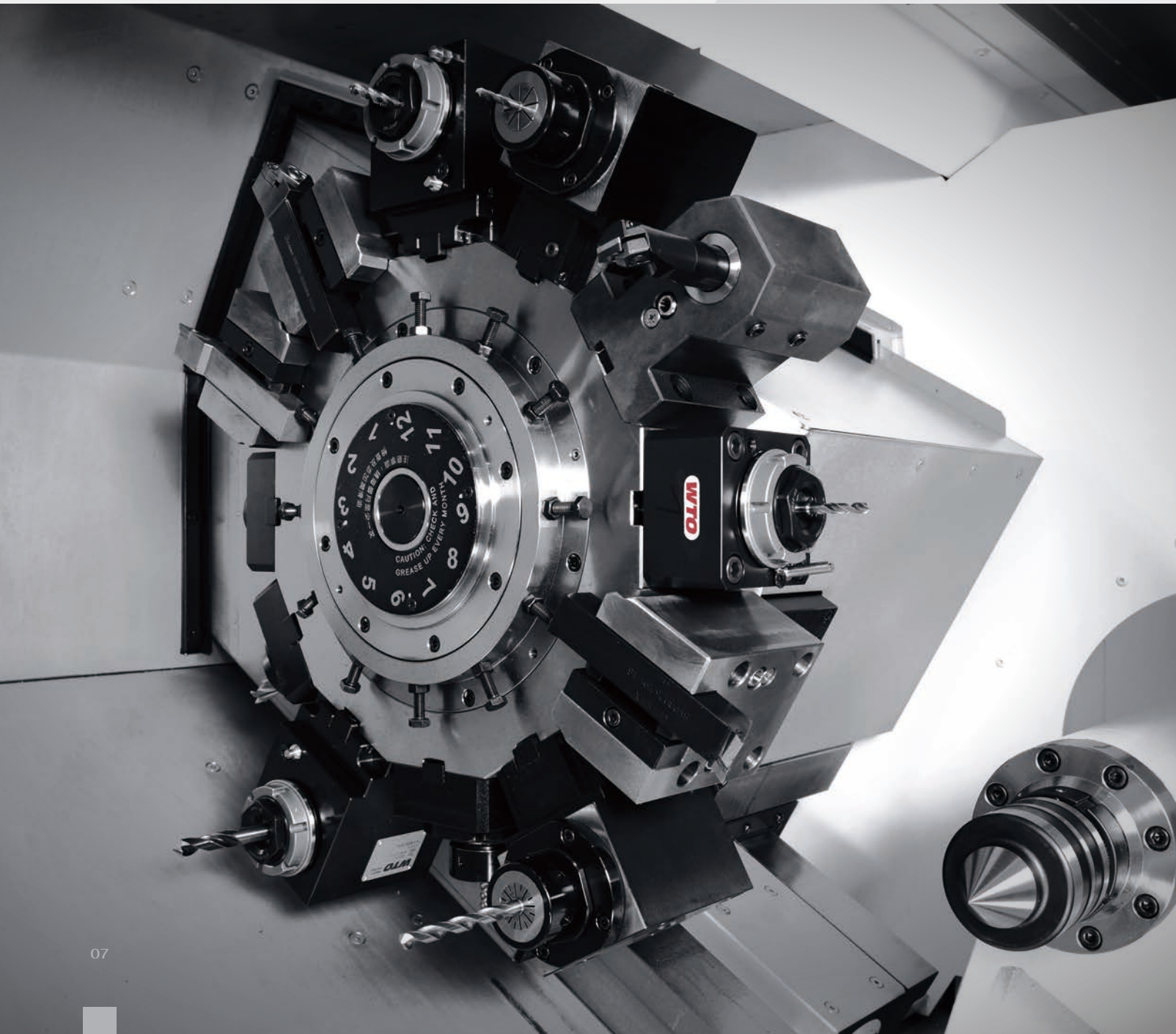

01

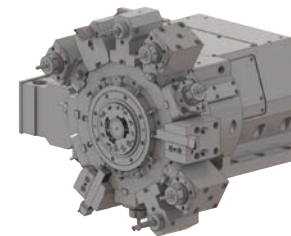

01 T12 Milling Turret

Number of Tools	12
OD Tool Shank Dimension	25 mm
ID Tool Shank Diameter	40 mm
Milling Shank Diameter	20 mm
Spindle Speed	4000 rpm
Motor Output	5.5 / 3.7 kw
Max. Torque	65.4 N-m

02

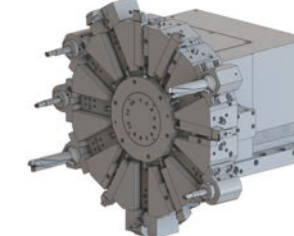

02 T12 Turning Turret (Standard)

Number of Tools	12
OD Tool Shank Dimension	25 mm
ID Tool Shank Diameter	40 mm

03

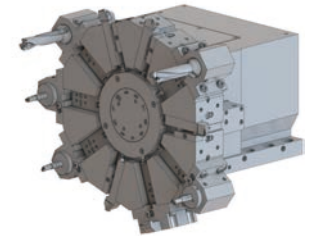

03 T10 Turning Turret (Option)

Number of Tools	10
OD Tool Shank Dimension	25 mm
ID Tool Shank Diameter	50 mm

Special Tool Holders

- 01** Gear Hobbing
- 02** Broaching
- 03** Power Skiving
- 04** Adjustable Angle Milling



Tailstock

The tailstock is a highly rigid design driven by a servo motor. Automation of the tailstock position and drilling synchronously during turning with a drill bit installed allows greatly reduced cycle times. The mandrel is available in fixed and rotary versions and the tailstock is pushed by oil pressure.

Special needs such as thrust size or mandrel form etc. can be assessed if customization is required.

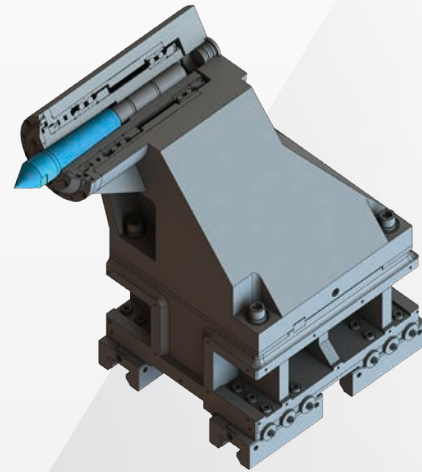

— Tailstock with Built-In Center has a larger load capacity than a fixed mandrel for large workpieces. (Option)

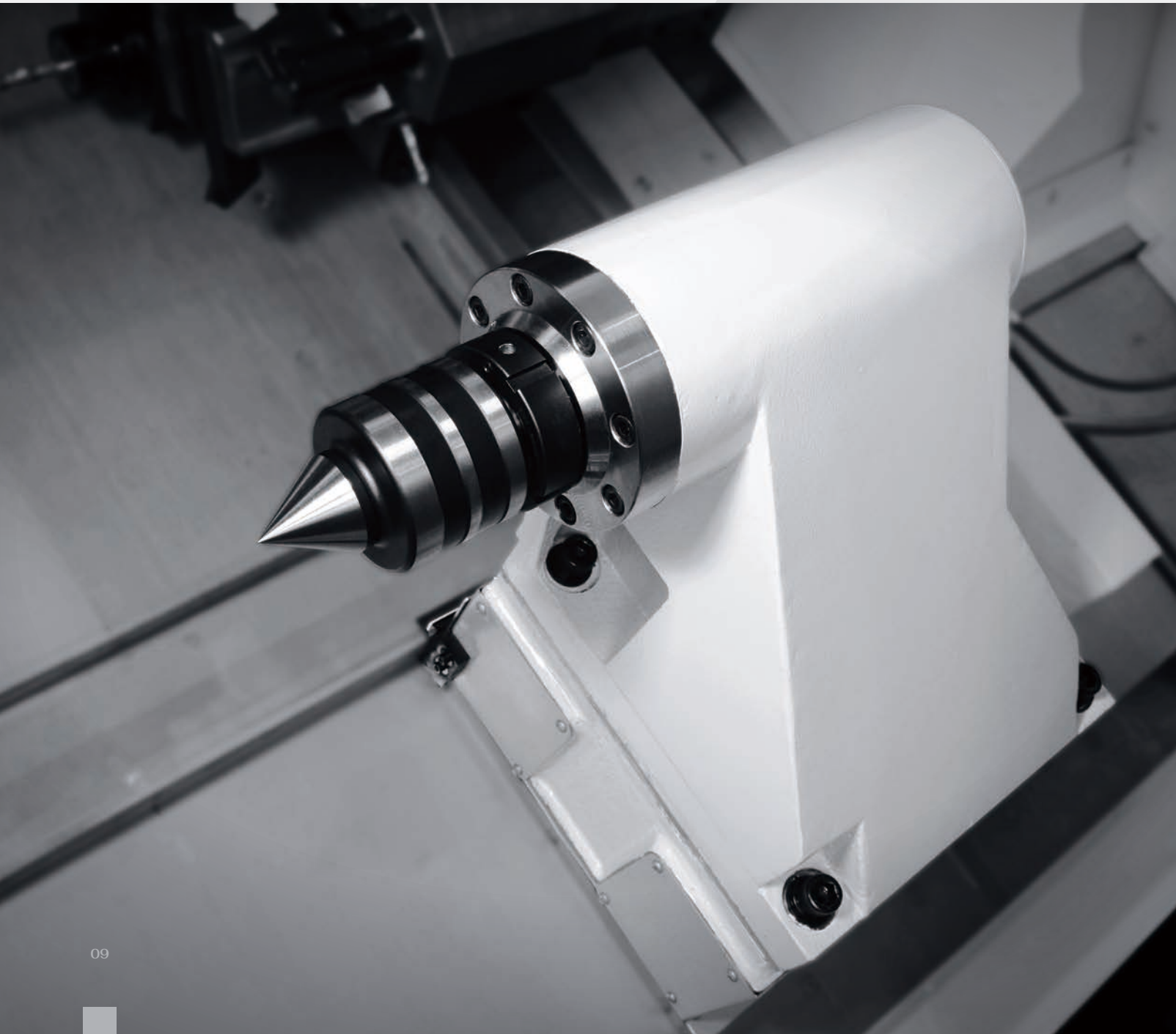

01 Servo Tailstock (Standard)

Tapered Bore Type	MT.5	
Tailstock Thrust	1 ~ 10	kN
Tailstock Travel	730	mm
Rapid Traverse	20	m/mm
Approach	7	m/mm
Retract	20	m/mm

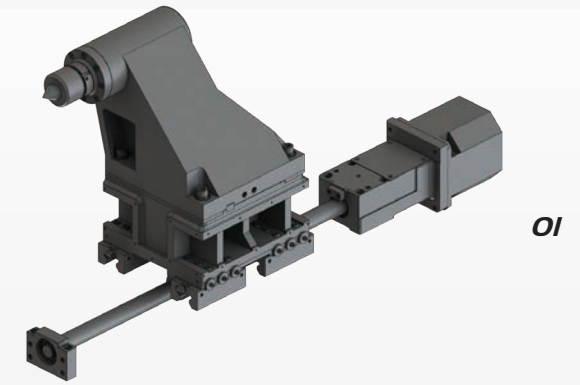

02 Servo Tailstock Function

Through the dialog UI interface, it is convenient to set the servo tailstock thrust and origin and other parameters.

Servo Tailstock

(ABSOLUTE)	(RELATIVE)	(MACHINE)	(DIST TO GO)
X: 0.000	X: 0.000	X: 0.000	X:
Z: 0.000	Z: 0.000	Z: 0.000	Z:
Y: 0.000	Y: 0.000	Y: 0.000	Y:
ZB:	ZB:	ZB:	ZB:

Thrust Setting

Now Thrust: 6.0 k, 612 kgf

Tail. Origin: 0.000

01 Steady Rest

Long workpieces provide stable centering while maintaining optimum machining accuracy.

02 Chip Conveyor

To assist with factory layout right, left, rear side chip conveyors are available. (L7 only)

Hinge Type Chip Conveyor

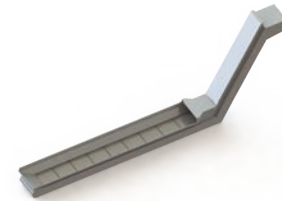

Scraper Type Chip Conveyor



Chip Type	Curly Metallic Chip Steel / Aluminum	Power Metallic Chip Foundry / Aluminum / Brass	Non-Metallic
Hinge Type	○	×	○
Scraper Type	×	○	×

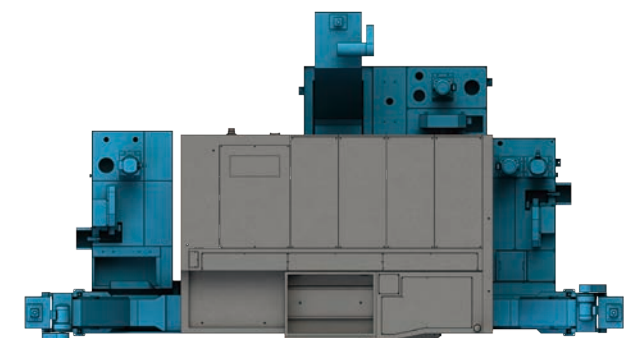
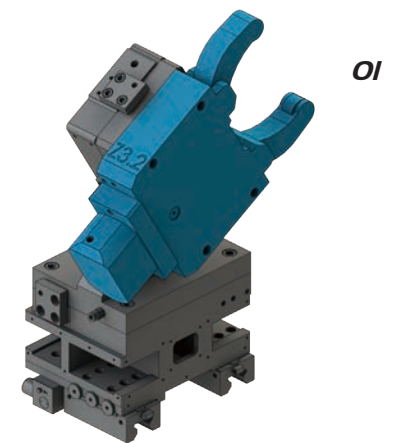

Interference & Travel Range

LX-2500 T12

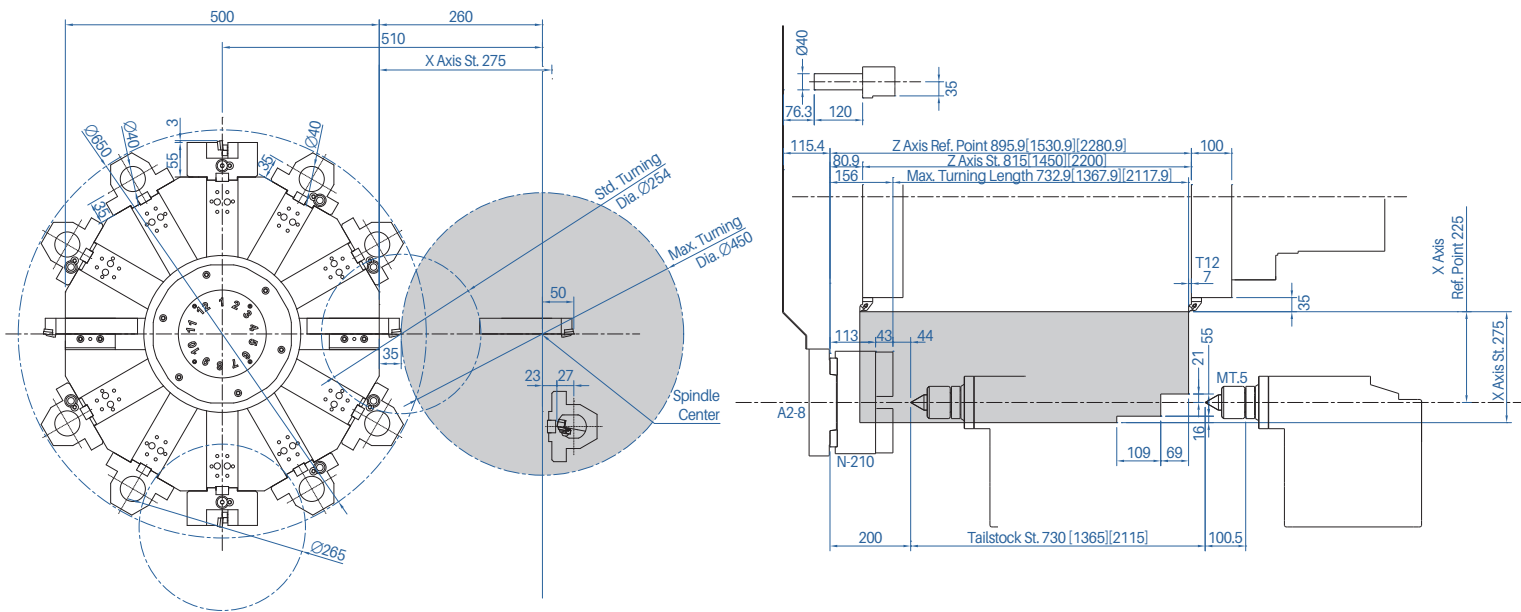

LX-2500M T12

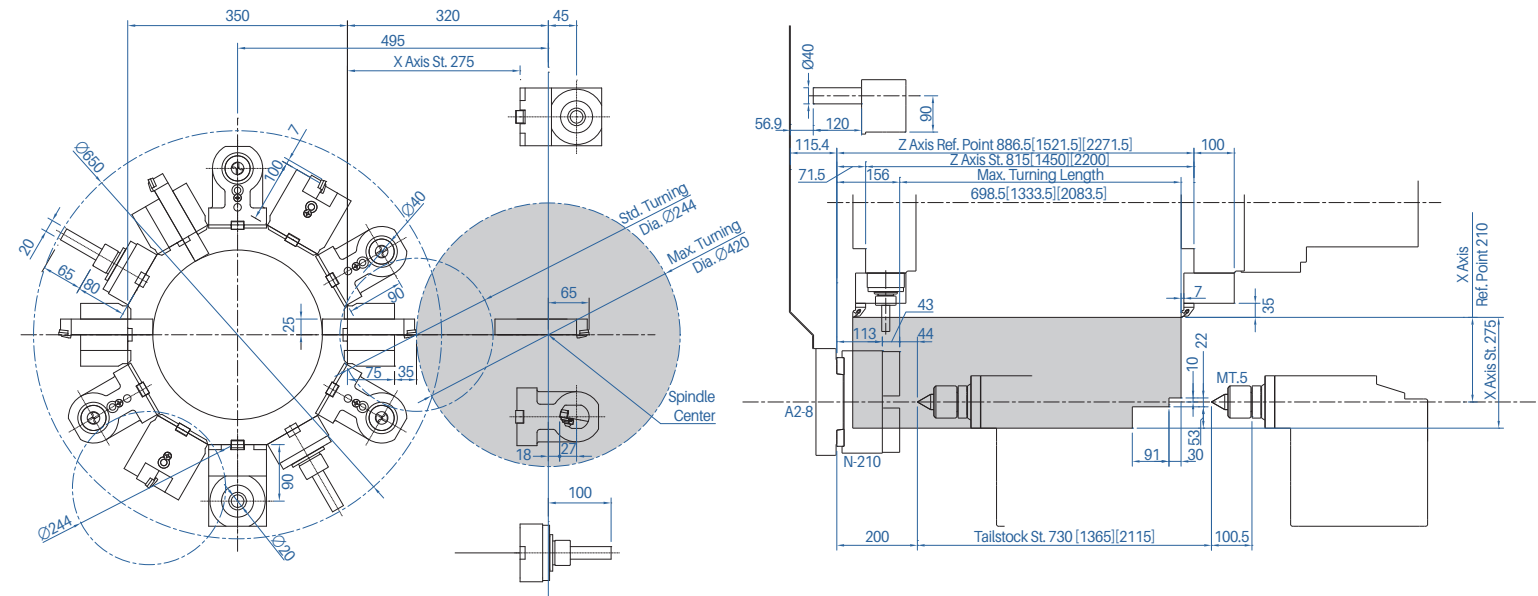

LX-2500 T10

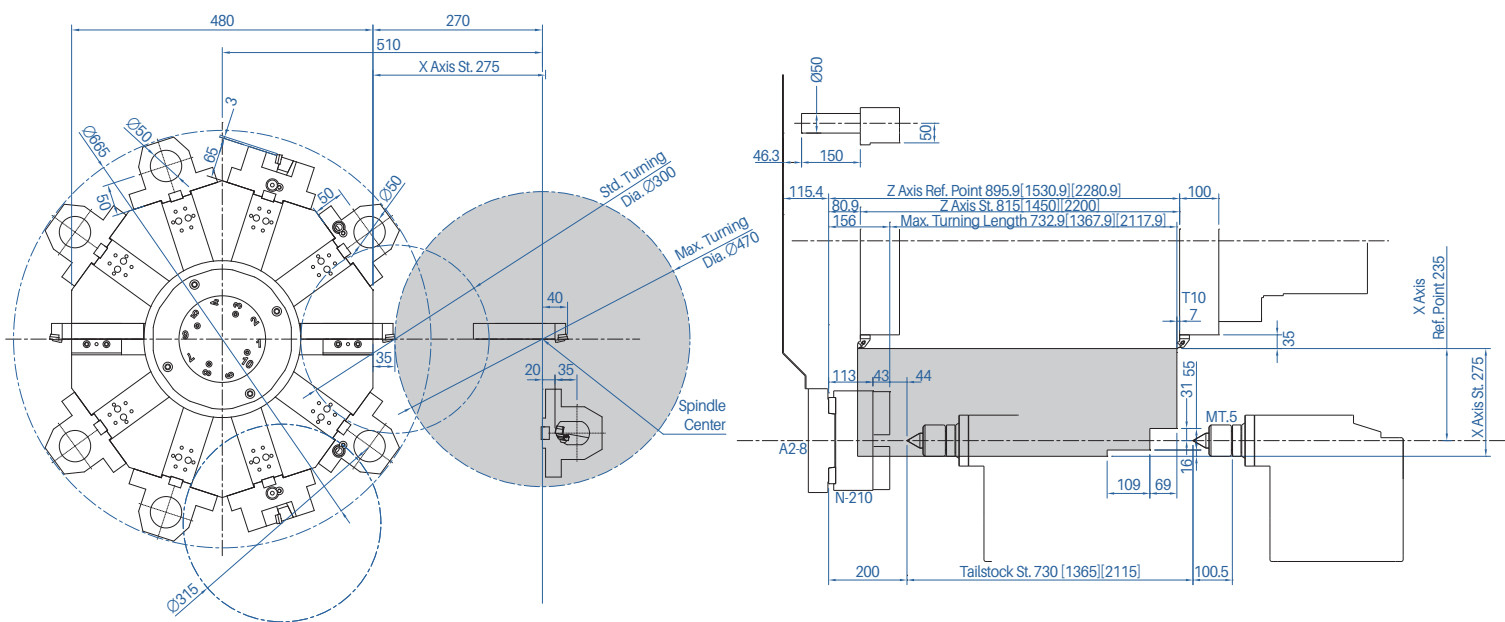

LX-2500Y T12

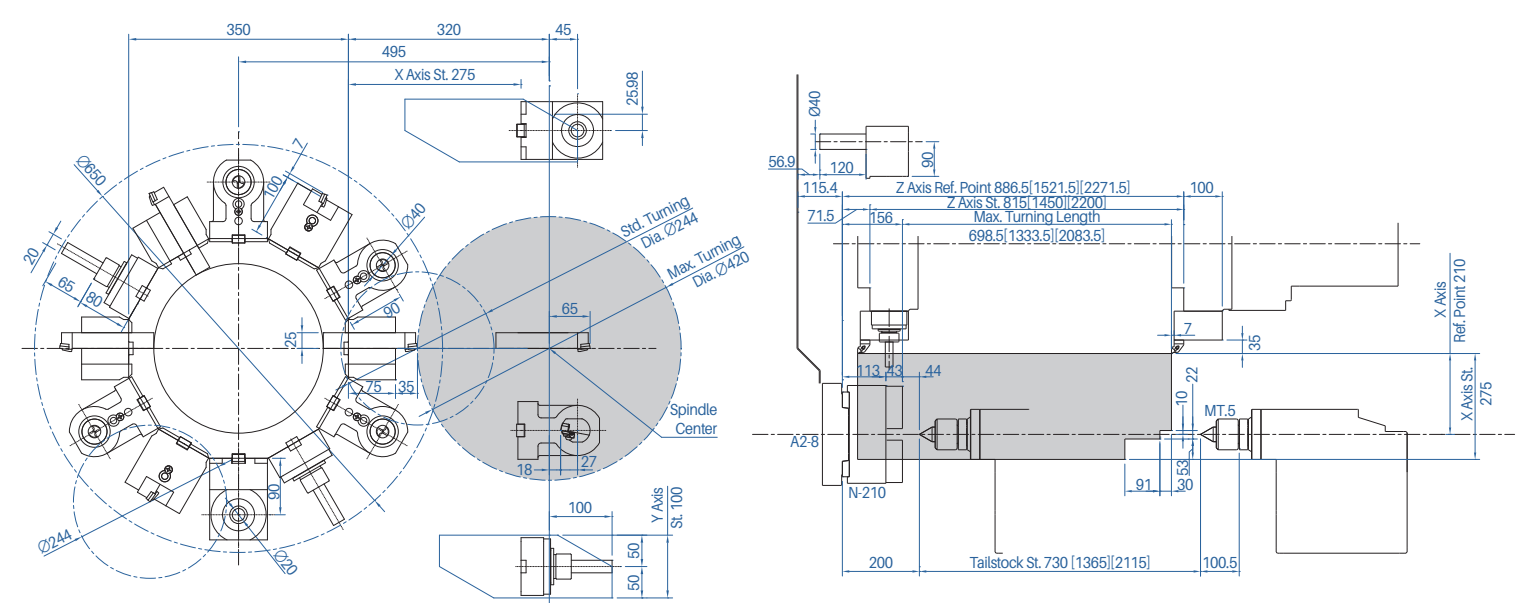

Interference & Travel Range

LX-3000 T12

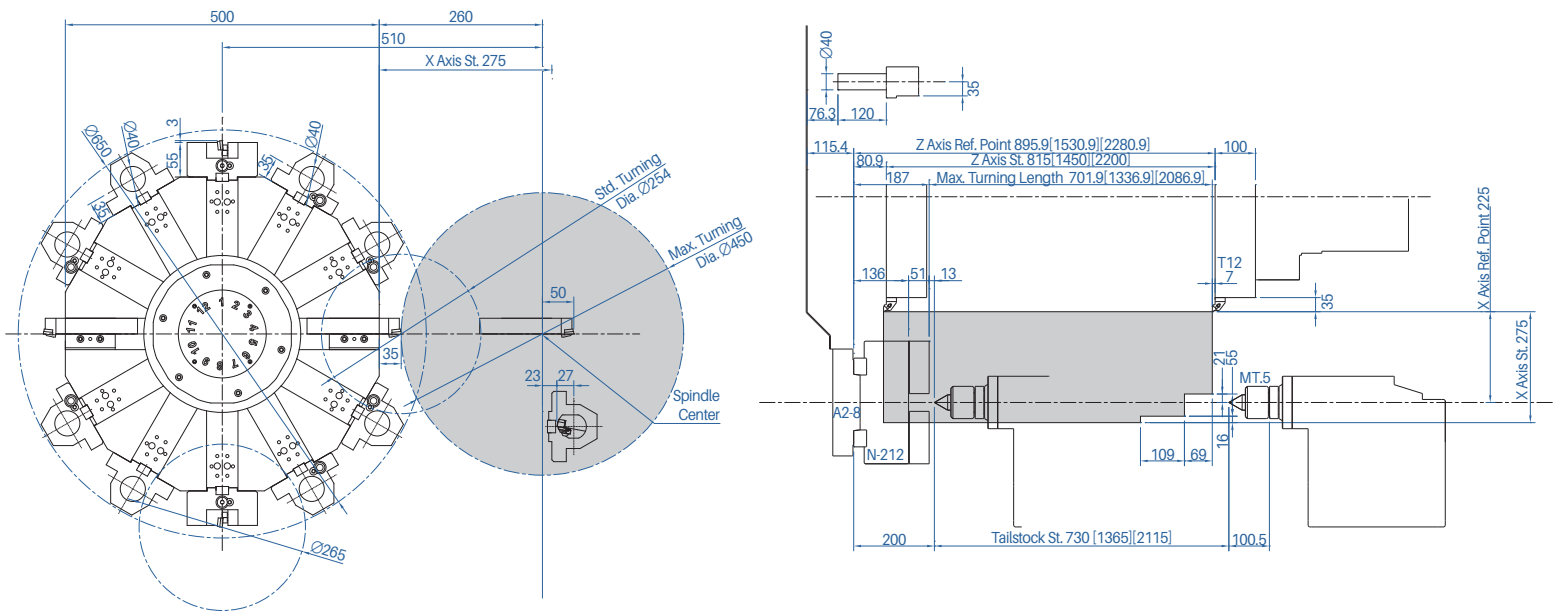

LX-3000M T12

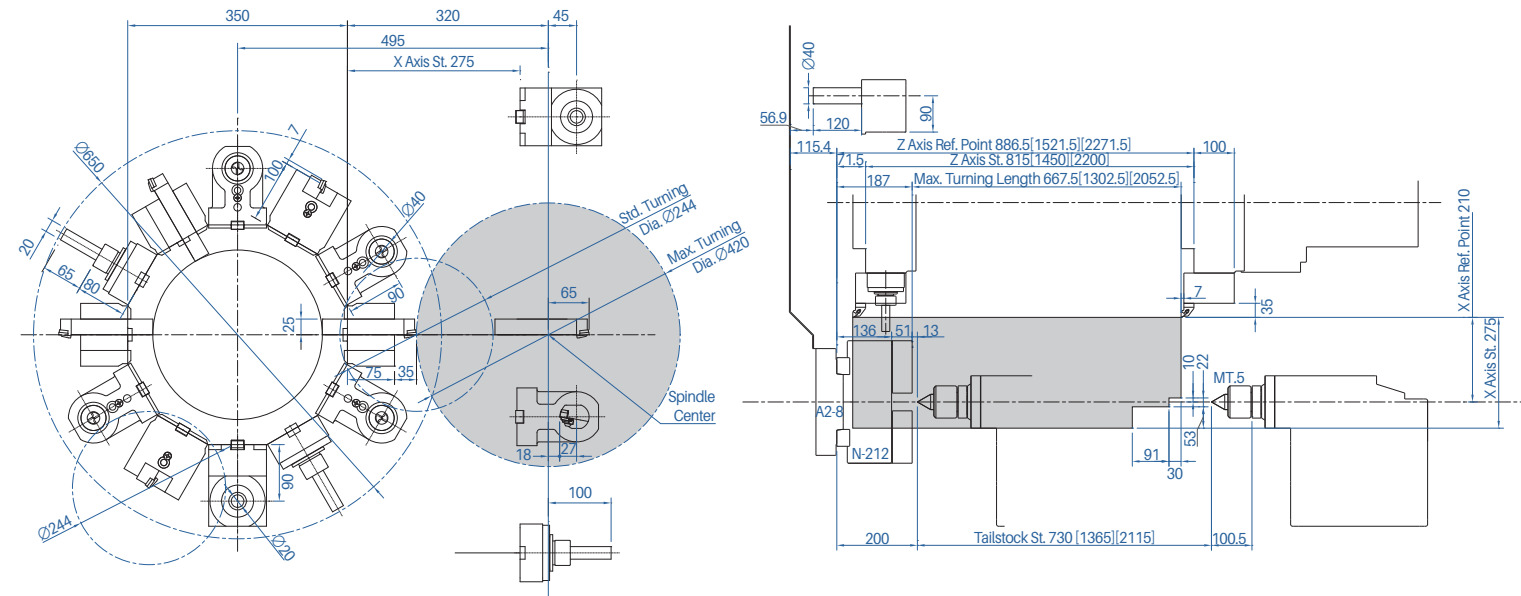

LX-3000 T10

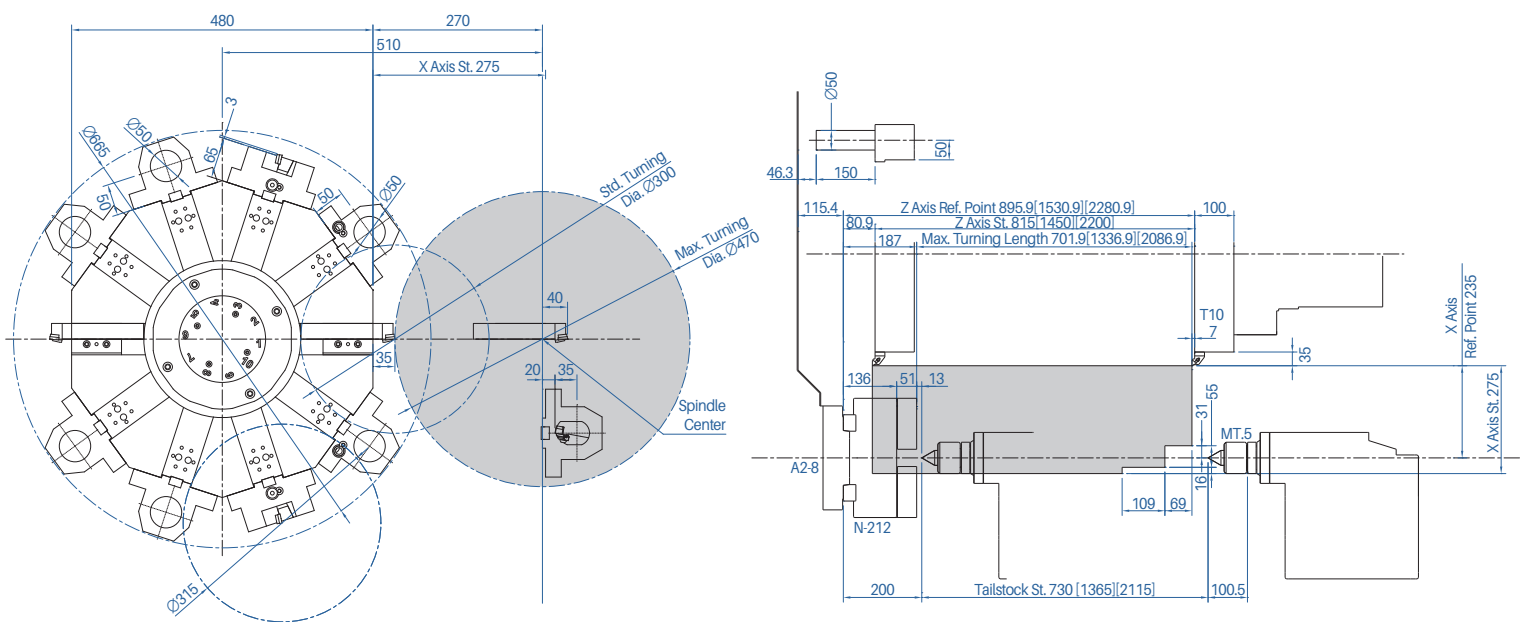

LX-3000Y T12

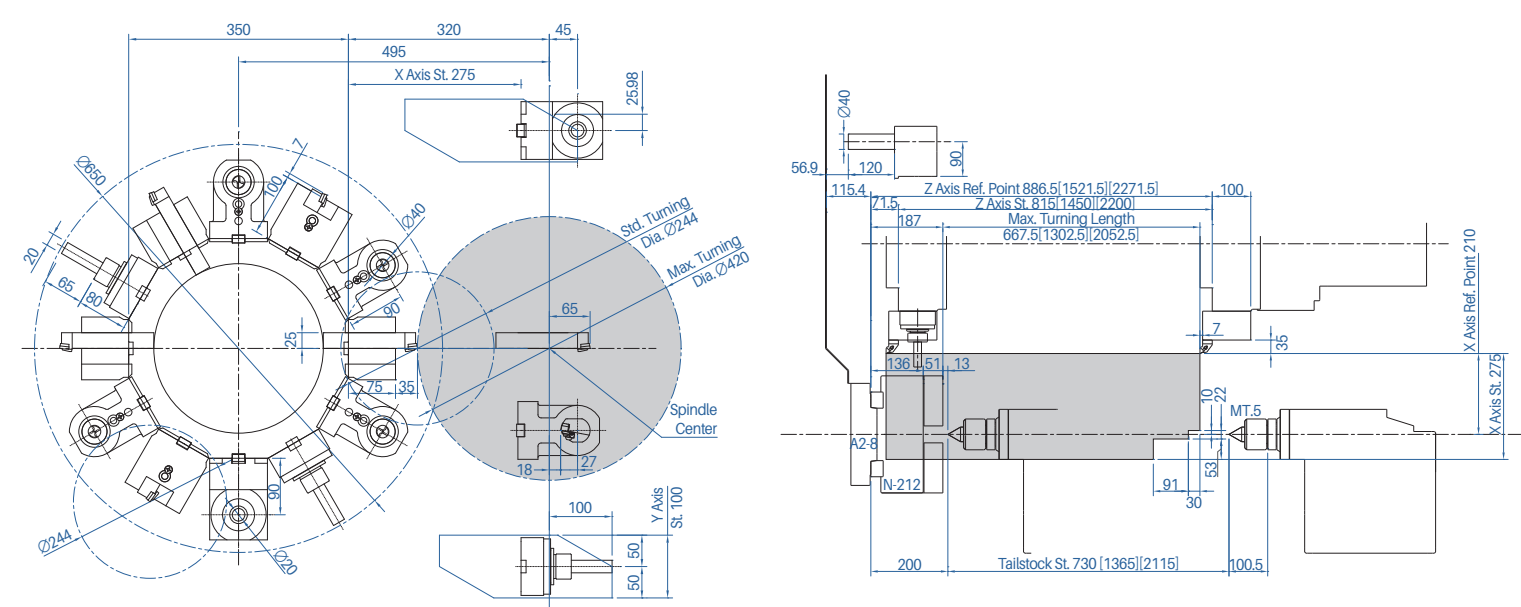

Machine Dimensions

LX-2500(M) L7 / LX-3000(M) L7

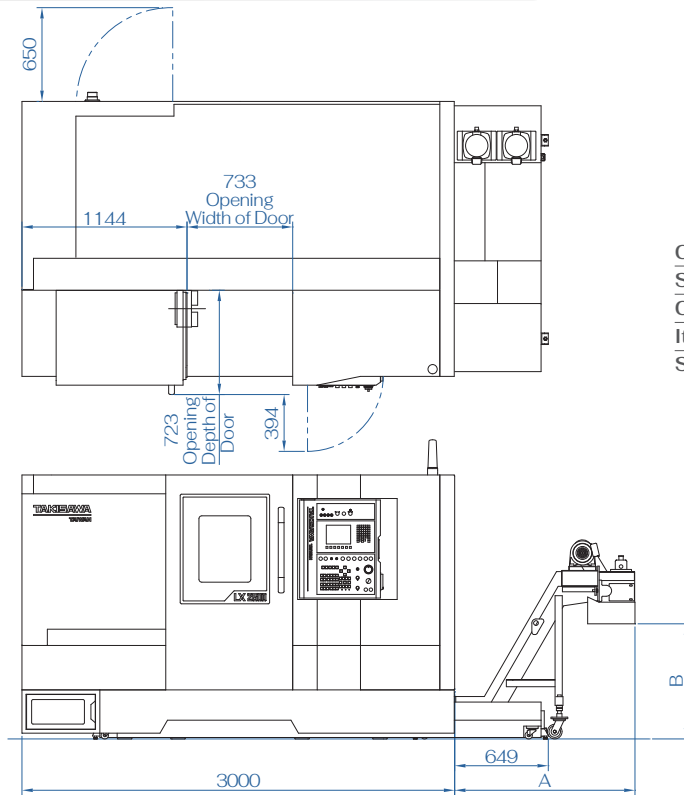

Chip Conveyor Dimension	A	B
Standard	1256	907
CE	1256	782
Italy	1481	1021
Switzerland	1481	1171

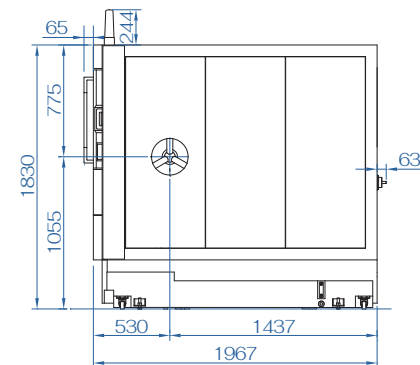

LX-2500(M) L13 / LX-3000(M) L13

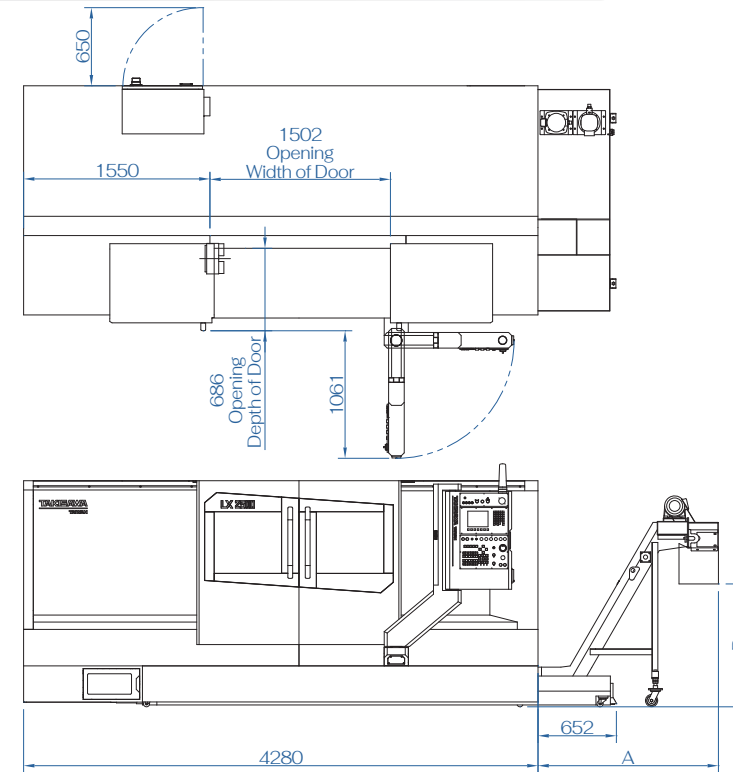

Chip Conveyor Dimension	A	B
Standard	1278	907
CE	1278	782
Italy	1503	1021
Switzerland	1503	1171

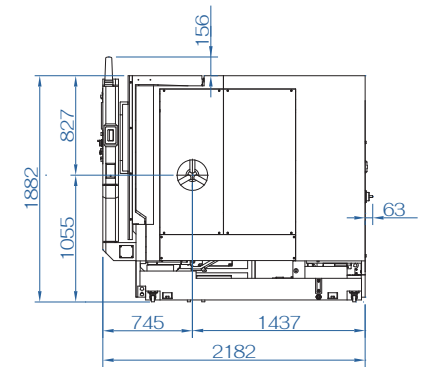

LX-2500Y L7 / LX-3000Y L7

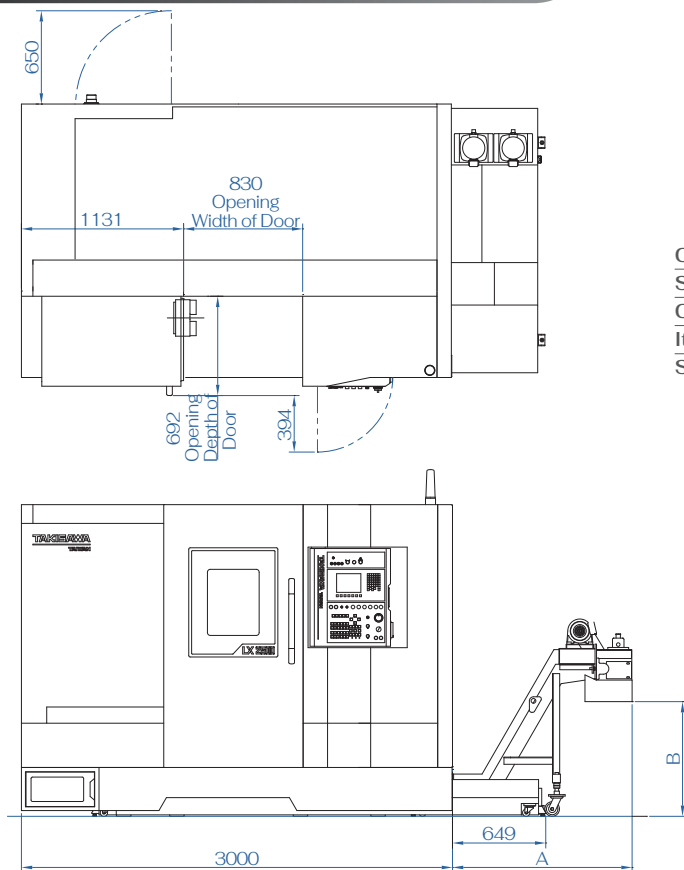

Chip Conveyor Dimension	A	B
Standard	1256	907
CE	1256	782
Italy	1481	1021
Switzerland	1481	1171

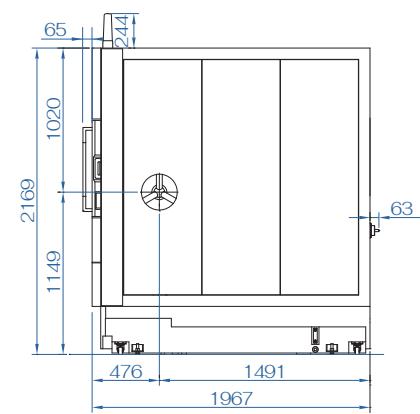

LX-2500Y L13 / LX-3000Y L13

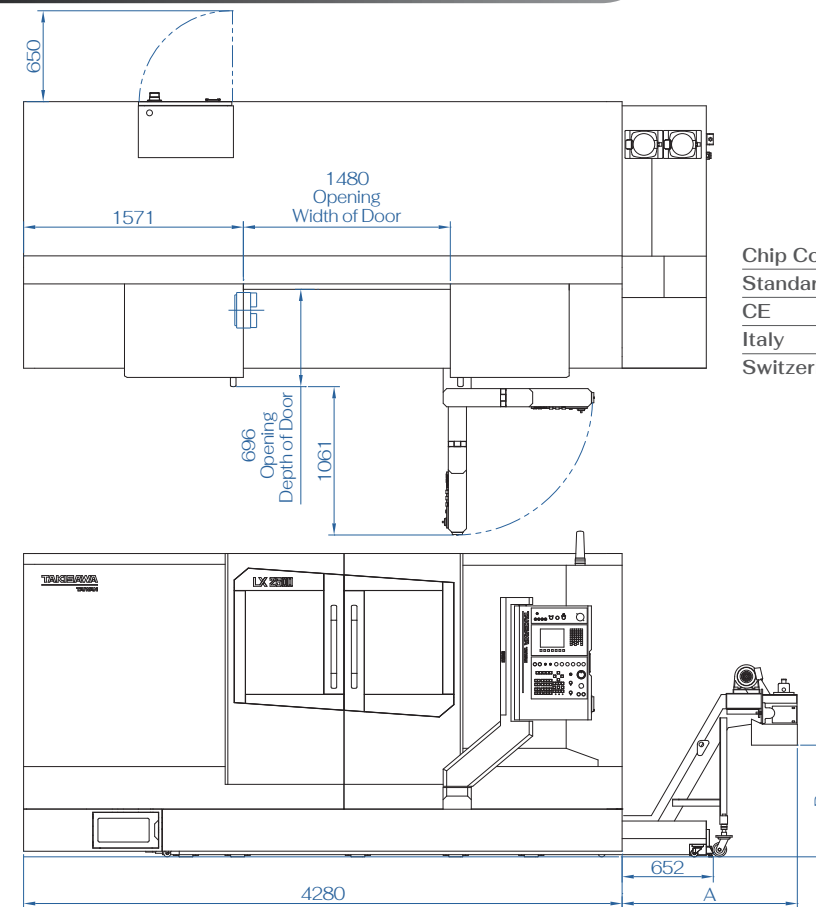

Chip Conveyor Dimension	A	B
Standard	1278	907
CE	1278	782
Italy	1503	1021
Switzerland	1503	1171

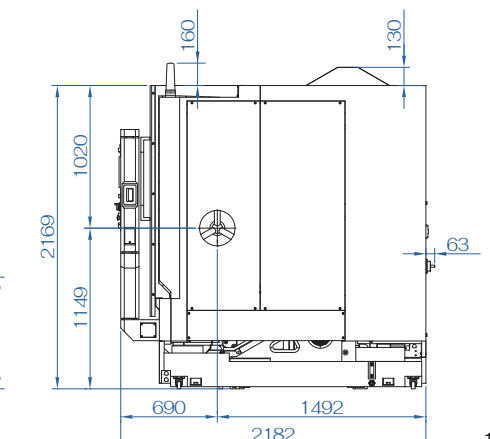

Machine Dimensions

LX-2500(M) L20 / LX-3000(M) L20

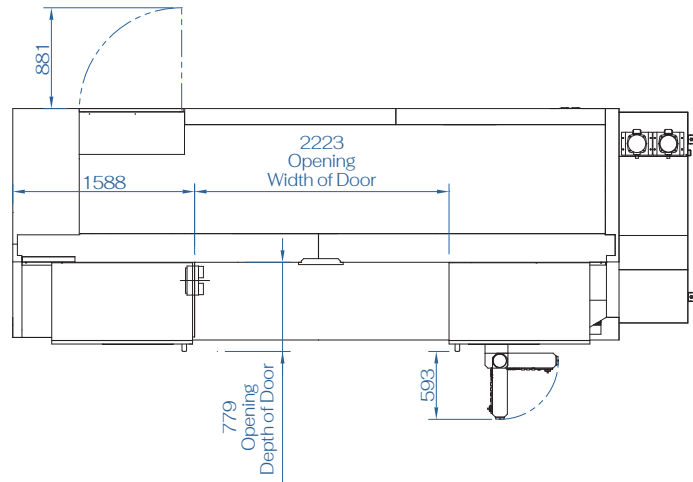

Chip Conveyor Dimension	A	B
Standard	1278	907
CE	1278	782
Italy	1503	1021
Switzerland	1503	1171

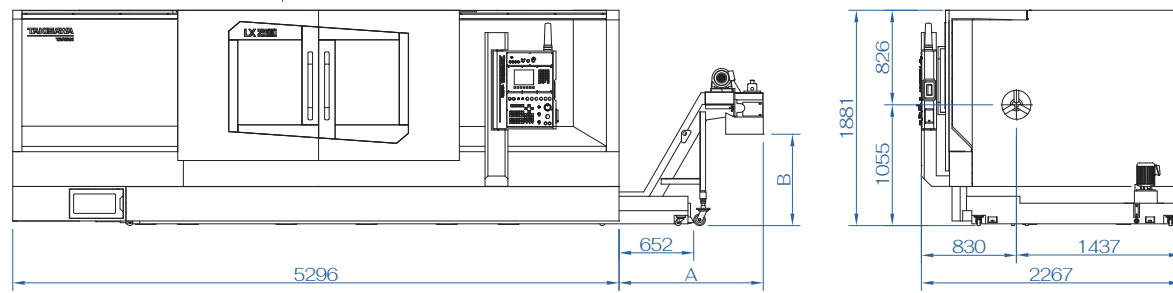

LX-2500Y L20 / LX-3000Y L20

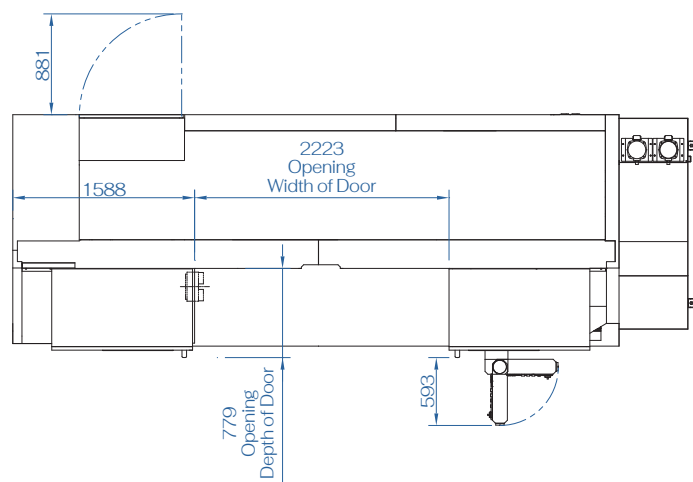

Chip Conveyor Dimension	A	B
Standard	1278	907
CE	1278	782
Italy	1503	1021
Switzerland	1503	1171

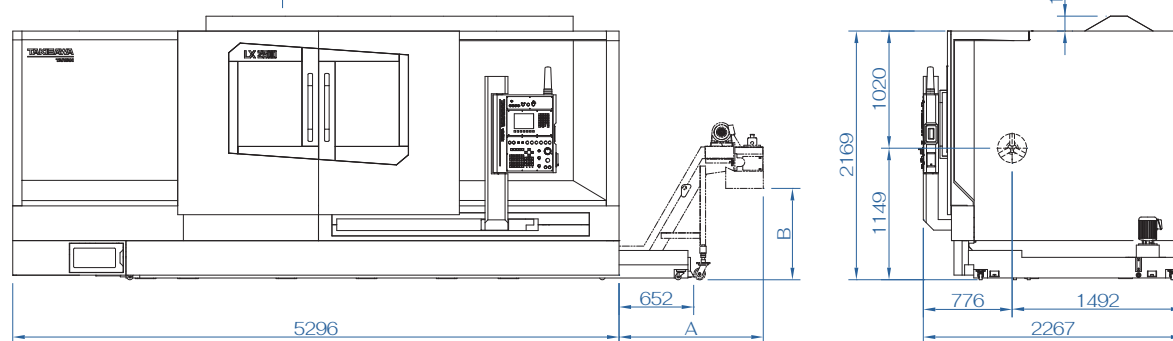

Tooling System

LX-2500 / LX-3000

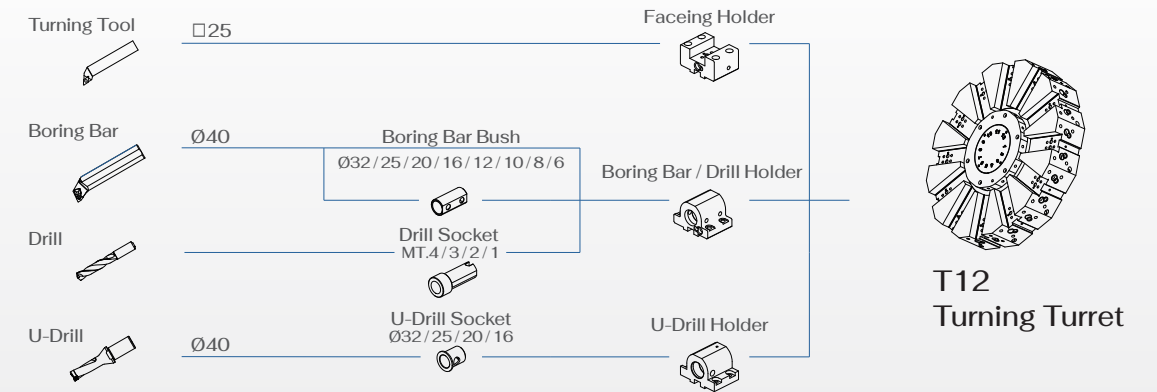

LX-2500 / LX-3000

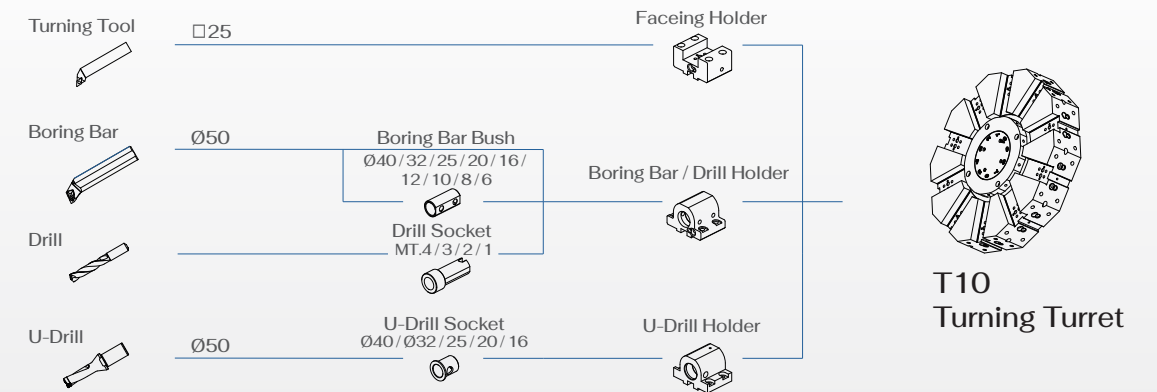

LX-2500M / Y

LX-3000M / Y

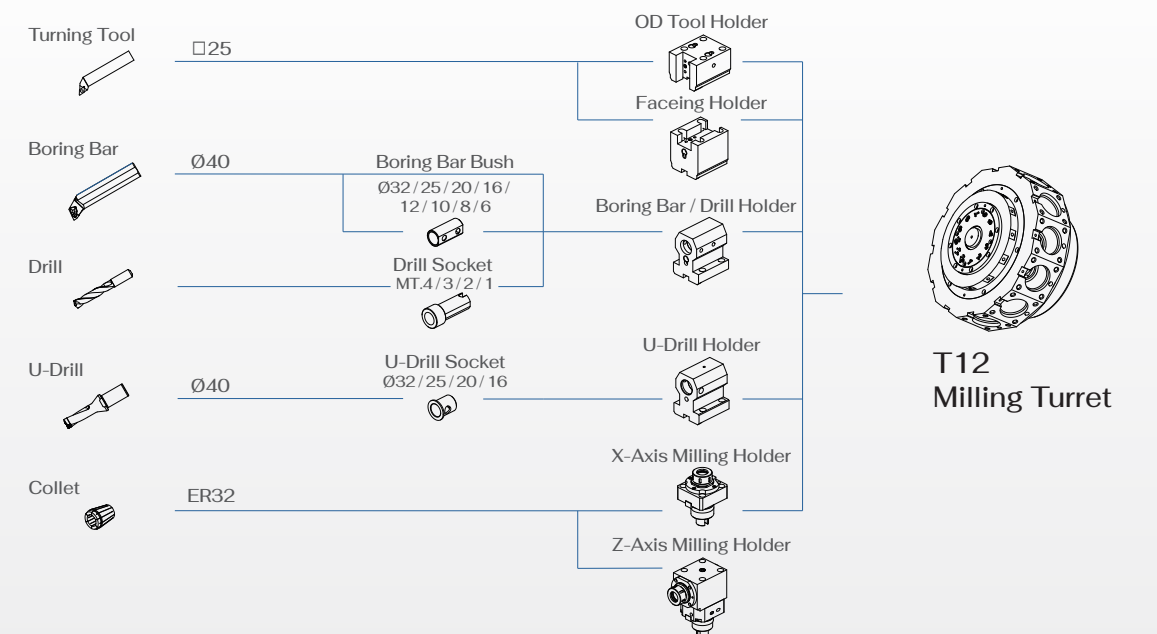

Machine Specifications

Item		LX-2500L7	LX-2500ML7	LX-2500YL7	LX-3000L7	LX-3000ML7	LX-3000YL7	
Capacity	Max. Swing	mm	625	625	730	625	625	730
	Standard Turning Diameter	mm	254 ^{T12} Turret	244	244	254 ^{T12} Turret	244	244
			300 ^{T10} Turret					
	Max. Turning Diameter	mm	450 ^{T12} Turret	420	420	450 ^{T12} Turret	420	420
			470 ^{T10} Turret					
	Max. Turning Length	mm	732	698	698	701	667	667
Max. Bar Work Capacity	mm	81 Built-In PMotor	81 Built-In PMotor	81 Built-In PMotor	90	90	90	
		75 GearBox	75 GearBox	75 GearBox				
Travel	X-Axis Travel	mm	275	275	275	275	275	
	Z-Axis Travel	mm	815	815	815	815	815	
	Y-Axis Travel	mm	-	-	± 50	-	-	± 50
	B-Axis Travel	mm	730	730	730	730	730	730
Spindle	Spindle Speed	rpm	3500 Built-In GearBox PMotor	3500 Built-In GearBox PMotor	3500 Built-In GearBox PMotor	2800	2800	2800
			[3000] PMotor	[3000] PMotor	[3000] PMotor			
	Spindle Nose		A2-8	A2-8	A2-8	A2-8	A2-8	A2-8
	Through Hole Diameter	mm	91 Built-In PMotor	91 Built-In PMotor	91 Built-In PMotor	102	102	102
		86 GearBox	86 GearBox	86 GearBox				
Bearing Inside Diameter	mm	120	120	120	140	140	140	
Turret	Number of Tools		T12	T12	T12	T12	T12	
			T10		T10		T10	
	OD Tool Shank Dimension	mm	25	25	25	25	25	25
	ID Tool Shank Diameter	mm	40 ^{T12} Turret	40	40	40 ^{T12} Turret	40	40
			50 ^{T10} Turret					
	Milling Shank Diameter	mm	-	20 ER32	20 ER32	-	20 ER32	20 ER32
Milling Spindle Speed	rpm	-	4000	4000	-	4000	4000	
Tailstock	Tailstock Type		Live Center	Live Center	Live Center	Live Center	Live Center	
			Built-In Center	Built-In Center	Built-In Center	Built-In Center	Built-In Center	
Tapered Bore Type		MT.5	MT.5	MT.5	MT.5	MT.5	MT.5	
Feedrate	X-Axis Rapid Traverse	m/min	24	24	24	24	24	
	Z-Axis Rapid Traverse	m/min	30	30	30	30	30	
	Y-Axis Rapid Traverse	m/min	-	-	10	-	-	10
	B-Axis Rapid Traverse	m/min	20	20	20	20	20	20
Motor	Spindle Motor	kw	22 / 15 Built-In	22 / 15 Built-In	22 / 15 Built-In	22 / 15 Built-In	22 / 15 Built-In	22 / 15 Built-In
			[22 / 18.5] GearBox	[22 / 18.5] GearBox	[22 / 18.5] GearBox	[22 / 18.5] GearBox	[22 / 18.5] GearBox	[22 / 18.5] GearBox
			18.5 / 15 PMotor GearBox	18.5 / 15 PMotor GearBox	18.5 / 15 PMotor GearBox	18.5 / 15 PMotor	18.5 / 15 PMotor	18.5 / 15 PMotor
	Milling Spindle Motor	kw	-	5.5 / 3.7	5.5 / 3.7	-	5.5 / 3.7	5.5 / 3.7
	Index Motor	kw	1.2	1.2	1.2	1.2	1.2	1.2
	X-Axis Servo Motor	kw	1.8	1.8	3	1.8	1.8	3
	Z-Axis Servo Motor	kw	3	3	3	3	3	3
	Y-Axis Servo Motor	kw	-	-	3	-	-	3
B-Axis Servo Motor	kw	2.5	2.5	2.5	2.5	2.5	2.5	
Machine Size	Height	mm	1830	1830	2169	1830	1830	2169
	Width	mm	3000	3000	3000	3000	3000	3000
	Depth	mm	1967	1967	1967	1967	1967	1967
	Weight	kg	6150	6250	6600	6250	6350	6700

[] Optional

Machine Specifications

Item		LX-2500L13	LX-2500ML13	LX-2500YL13	LX-3000L13	LX-3000ML13	LX-3000YL13	
Capacity	Max. Swing	mm	625	625	730	625	625	730
	Standard Turning Diameter	mm	254 ^{T12} Turret	244	244	254 ^{T12} Turret	244	244
			300 ^{T10} Turret					
	Max. Turning Diameter	mm	450 ^{T12} Turret	420	420	450 ^{T12} Turret	420	420
			470 ^{T10} Turret					
	Max. Turning Length	mm	1367	1333	1333	1336	1302	1302
Max. Bar Work Capacity	mm	81 Built-In PMotor	81 Built-In PMotor	81 Built-In PMotor	90	90	90	
		75 GearBox	75 GearBox	75 GearBox				
Travel	X-Axis Travel	mm	275	275	275	275	275	
	Z-Axis Travel	mm	1450	1450	1450	1450	1450	
	Y-Axis Travel	mm	-	-	± 50	-	-	± 50
	B-Axis Travel	mm	1365	1365	1365	1365	1365	1365
Spindle	Spindle Speed	rpm	3500 Built-In GearBox PMotor	3500 Built-In GearBox PMotor	3500 Built-In GearBox PMotor	2800	2800	2800
			[3000] PMotor	[3000] PMotor	[3000] PMotor			
	Spindle Nose		A2-8	A2-8	A2-8	A2-8	A2-8	A2-8
	Through Hole Diameter	mm	91 Built-In PMotor	91 Built-In PMotor	91 Built-In PMotor	102	102	102
		86 GearBox	86 GearBox	86 GearBox				
Bearing Inside Diameter	mm	120	120	120	140	140	140	
Turret	Number of Tools		T12	T12	T12	T12	T12	
			T10		T10		T10	
	OD Tool Shank Dimension	mm	25	25	25	25	25	25
	ID Tool Shank Diameter	mm	40 ^{T12} Turret	40	40	40 ^{T12} Turret	40	40
			50 ^{T10} Turret					
	Milling Shank Diameter	mm	-	20 ER32	20 ER32	-	20 ER32	20 ER32
Milling Spindle Speed	rpm	-	4000	4000	-	4000	4000	
Tailstock	Tailstock Type		Live Center	Live Center	Live Center	Live Center	Live Center	
			Built-In Center	Built-In Center	Built-In Center	Built-In Center	Built-In Center	
Tapered Bore Type		MT.5	MT.5	MT.5	MT.5	MT.5	MT.5	
Feedrate	X-Axis Rapid Traverse	m/min	24	24	24	24	24	
	Z-Axis Rapid Traverse	m/min	30	30	30	30	30	
	Y-Axis Rapid Traverse	m/min	-	-	10	-	-	10
	B-Axis Rapid Traverse	m/min	20	20	20	20	20	20
Motor	Spindle Motor	kw	22 / 15 Built-In	22 / 15 Built-In	22 / 15 Built-In	22 / 15 Built-In	22 / 15 Built-In	22 / 15 Built-In
			[22 / 18.5] GearBox	[22 / 18.5] GearBox	[22 / 18.5] GearBox	[22 / 18.5] GearBox	[22 / 18.5] GearBox	[22 / 18.5] GearBox
			18.5 / 15 PMotor GearBox	18.5 / 15 PMotor GearBox	18.5 / 15 PMotor GearBox	18.5 / 15 PMotor	18.5 / 15 PMotor	18.5 / 15 PMotor
	Milling Spindle Motor	kw	-	5.5 / 3.7	5.5 / 3.7	-	5.5 / 3.7	5.5 / 3.7
	Index Motor	kw	1.2	1.2	1.2	1.2	1.2	1.2
	X-Axis Servo Motor	kw	1.8	1.8	3	1.8	1.8	3
	Z-Axis Servo Motor	kw	3	3	3	3	3	3
	Y-Axis Servo Motor	kw	-	-	3	-	-	3
B-Axis Servo Motor	kw	2.5	2.5	2.5	2.5	2.5	2.5	
Machine Size	Height	mm	1882	1882	2169	1882	1882	2169
	Width	mm	4280	4280	4280	4280	4280	4280
	Depth	mm	2182	2182	2182	2182	2182	2182
	Weight	kg	7550	7650	8000	7650	7750	8100

[] Optional

Machine Specifications

Item		LX-2500L20	LX-2500ML20	LX-2500YL20	LX-3000L20	LX-3000ML20	LX-3000YL20
Capacity	Max. Swing mm	625	625	730	625	625	730
	Standard Turning Diameter mm	254 T12 Turret	244	244	254 T12 Turret	244	244
		300 T10 Turret			300 T10 Turret		
	Max. Turning Diameter mm	450 T12 Turret	420	420	450 T12 Turret	420	420
		470 T10 Turret			470 T10 Turret		
	Max. Turning Length mm	2117	2083	2083	2086	2052	2052
Max. Bar Work Capacity mm	81 Built-In PMotor	81 Built-In PMotor	81 Built-In PMotor	90	90	90	
	75 GearBox	75 GearBox	75 GearBox				
Travel	X-Axis Travel mm	275	275	275	275	275	275
	Z-Axis Travel mm	2200	2200	2200	2200	2200	2200
	Y-Axis Travel mm	-	-	± 50	-	-	± 50
	B-Axis Travel mm	2115	2115	2115	2115	2115	2115
Spindle	Spindle Speed rpm	3500 Built-In GearBox PMotor	3500 Built-In GearBox PMotor	3500 Built-In GearBox PMotor	2800	2800	2800
		[3000] PMotor	[3000] PMotor	[3000] PMotor			
	Spindle Nose	A2-8	A2-8	A2-8	A2-8	A2-8	A2-8
	Through Hole Diameter mm	91 Built-In PMotor	91 Built-In PMotor	91 Built-In PMotor	102	102	102
86 GearBox		86 GearBox	86 GearBox				
Bearing Inside Diameter mm	120	120	120	140	140	140	
Turret	Number of Tools	T12	T12	T12	T12	T12	T12
		T10			T10		
	OD Tool Shank Dimension mm	25	25	25	25	25	25
	ID Tool Shank Diameter mm	40 T12 Turret	40	40	40 T12 Turret	40	40
		50 T10 Turret			50 T10 Turret		
Milling Shank Diameter mm	-	20 ER32	20 ER32	-	20 ER32	20 ER32	
Milling Spindle Speed rpm	-	4000	4000	-	4000	4000	
Tailstock	Tailstock Type	Live Center	Live Center	Live Center	Live Center	Live Center	Live Center
		Built-In Center	Built-In Center	Built-In Center	Built-In Center	Built-In Center	Built-In Center
Tapered Bore Type	MT.5	MT.5	MT.5	MT.5	MT.5	MT.5	
Feedrate	X-Axis Rapid Traverse m/min	24	24	24	24	24	24
	Z-Axis Rapid Traverse m/min	30	30	30	30	30	30
	Y-Axis Rapid Traverse m/min	-	-	10	-	-	10
	B-Axis Rapid Traverse m/min	20	20	20	20	20	20
Motor	Spindle Motor kw	22 / 15 Built-In	22 / 15 Built-In	22 / 15 Built-In	22 / 15 Built-In	22 / 15 Built-In	22 / 15 Built-In
		[22 / 18.5] GearBox	[22 / 18.5] GearBox	[22 / 18.5] GearBox	[22 / 18.5] GearBox	[22 / 18.5] GearBox	[22 / 18.5] GearBox
		18.5 / 15 PMotor GearBox	18.5 / 15 PMotor GearBox	18.5 / 15 PMotor GearBox	18.5 / 15 PMotor	18.5 / 15 PMotor	18.5 / 15 PMotor
	Milling Spindle Motor kw	-	5.5 / 3.7	5.5 / 3.7	-	5.5 / 3.7	5.5 / 3.7
	Index Motor kw	1.2	1.2	1.2	1.2	1.2	1.2
	X-Axis Servo Motor kw	3	3	3	3	3	3
	Z-Axis Servo Motor kw	7	7	7	7	7	7
Y-Axis Servo Motor kw	-	-	3	-	-	3	
B-Axis Servo Motor kw	3	3	3	3	3	3	
Machine Size	Height mm	1881	1881	2169	1881	1881	2169
	Width mm	5296	5296	5296	5296	5296	5296
	Depth mm	2267	2267	2267	2267	2267	2267
	Weight kg	8550	8650	9000	8650	8750	9100

[] Optional

Standard and Optional Accessories

Accessories	LX-2500	LX-2500M	LX-2500Y	LX-3000	LX-3000M	LX-3000Y
Built-In Motor Spindle	●	●	●	●	●	●
GearBox Spindle	◎	◎	◎	◎	◎	◎
P Motor Spindle	◎	◎	◎	◎	◎	◎
Servo Tailstock with Live Center	●	●	●	●	●	●
Servo Tailstock with Built-In Center	◎	◎	◎	◎	◎	◎
T10 Turning Turret	◎	-	-	◎	-	-
T12 Turning Turret	●	-	-	●	-	-
T12 Milling Turret	-	●	●	-	●	●
OD Tool Holder	-	●	●	-	●	●
Face Tool Holder	●	●	●	●	●	●
U-Drill Tool Holder	●	●	●	●	●	●
Boring Bar Tool Holder	●	●	●	●	●	●
Boring Bar Bush (Ø6, Ø8, Ø10, Ø12)	●	●	●	●	●	●
Boring Bar Bush (Ø16, Ø20, Ø25, Ø32)	●	●	●	●	●	●
Boring Bar Bush (Ø40) T10 Only	●	-	-	●	-	-
U-Drill Bush (Ø16, Ø20, Ø25, Ø32)	●	●	●	●	●	●
U-Drill Bush (Ø40) T10 Only	●	●	●	●	●	●
Drill Bush (MT.1, MT.2, MT.3, MT.4)	◎	◎	◎	◎	◎	◎
X-Axis Milling Holder	-	●	●	-	●	●
Z-Axis Milling Holder	-	●	●	-	●	●
Automatic Tool Setter	◎	◎	◎	◎	◎	◎
Manual Tool Setter	◎	◎	◎	◎	◎	◎
Linear Scales	◎	◎	◎	◎	◎	◎
Coolant Pump (400W)	●	●	●	●	●	●
Coolant Pump (715W, 750W, 900W, 1400W)	◎	◎	◎	◎	◎	◎
Cutting Fluid Cooling	◎	◎	◎	◎	◎	◎
Hydraulic System	●	●	●	●	●	●
Nut Cooling Ball Screw	◎	◎	◎	◎	◎	◎
High Pressure Coolant	◎	◎	◎	◎	◎	◎
Hydraulic Oil Cooling	◎	◎	◎	◎	◎	◎
Hydraulic Pressure Sensor	●	●	●	●	●	●
Lubrication System	●	●	●	●	●	●
Lubricating Oil Recycling Box	●	●	●	●	●	●
Hydraulic Chuck	●	●	●	●	●	●
Collet Chuck	◎	◎	◎	◎	◎	◎
Foot Switch	●	●	●	●	●	●
LED Interior Light	●	●	●	●	●	●
LED TAKISAWA Light	●	●	●	●	●	●
LED Signal Tower	●	●	●	●	●	●
Hydraulic Steady Rest	◎	◎	◎	◎	◎	◎
Manual Steady Rest	◎	◎	◎	◎	◎	◎
Right Side Chip Conveyor	◎	◎	◎	◎	◎	◎
Rear Side Chip Conveyor	◎	◎	◎	◎	◎	◎
Chip Cart	●	●	●	●	●	●
Parts Catcher	◎	◎	◎	◎	◎	◎
Parts Conveyor	◎	◎	◎	◎	◎	◎
Automatic Bar Feeder and Interface	◎	◎	◎	◎	◎	◎
Electrical Auto Door	◎	◎	◎	◎	◎	◎
Pneumatic Auto Door	◎	◎	◎	◎	◎	◎
Safety Door Switch	◎	◎	◎	◎	◎	◎
Safety Light Curtain	◎	◎	◎	◎	◎	◎
Air Blow	◎	◎	◎	◎	◎	◎
Oil Skimmer	◎	◎	◎	◎	◎	◎
Oil Mist Collector	◎	◎	◎	◎	◎	◎
Parts Counter	◎	◎	◎	◎	◎	◎
Automatic Power-Off	◎	◎	◎	◎	◎	◎

● Standard ◎ Optional - Nope

Special Specification Example

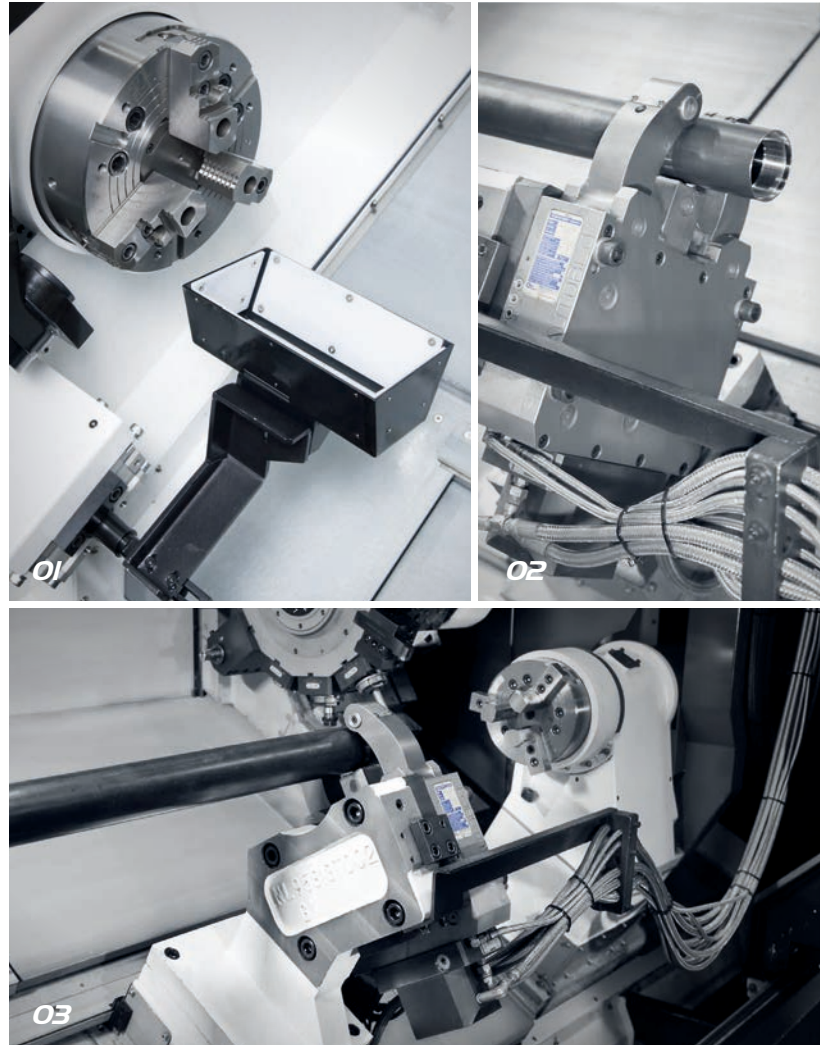

For any special needs such as changes in the specification of the work piece catcher and the centre frame please contact us for a customised needs assessment.

01 Parts Catcher

Max. Catching Diameter	90	mm
Max. Catching Length	210	mm
Max. Catching Weight	3	kg

02 Hydraulic Steady Rest

SMW SLU-Z-1	Ø4 ~ Ø64	mm
SMW SLU-Z-2	Ø8 ~ Ø101	mm
SMW SLU-Z-3	Ø12 ~ Ø152	mm
SMW SLU-Z-3.1	Ø20 ~ Ø165	mm
SMW SLU-Z-3.2	Ø50 ~ Ø200	mm

Manual Steady Rest

T006	Ø50 ~ Ø155	mm
T009	Ø100 ~ Ø240	mm
T011	Ø8 ~ Ø80	mm
T012	Ø20 ~ Ø200	mm

03 Sub. Spindle (without Motor)

Spindle Nose	A2-6
--------------	------

High Speed Gantry Loader System

Layout Variations



Peripheral Equipment

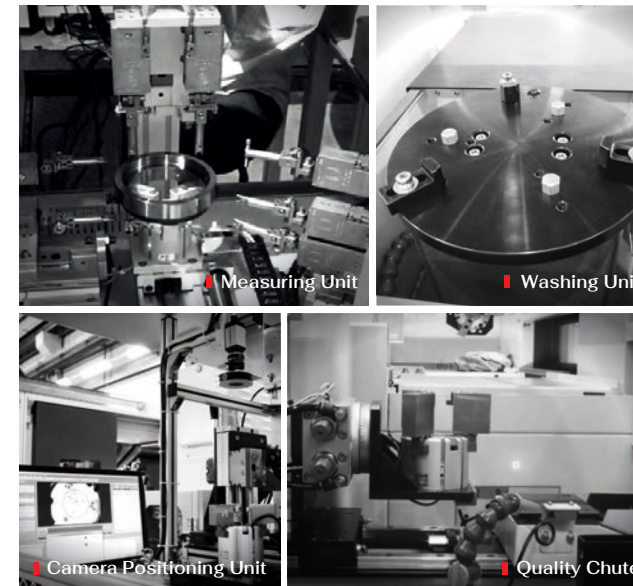

Gantry Loader Specifications

Feedrate		
X-Axis Rapid Traverse	180	m/min
Z-Axis Rapid Traverse	150	m/min
Working Size		
OD	160	mm
Length	100	mm
Weight	3 (x2)	kg

Work Feeder Specifications

Pallet	16	pcs
Loading Weight	40	kg
Max. Height	450	mm
Worker Feeder Width	610	mm

Highly Accurate Optional Equipment

There are special requirements for precise machining accuracy and it is necessary to use approved high-precision optional equipment.

Please contact us for advice on these options.

- 01 Linear Scales
- 02 Automatic | Manual Tool Setter
- 03 Nut Cooling Ball Screw
- 04 Cutting Fluid Cooling
- 05 High Pressure Coolant
- 06 Hydraulic Oil Cooling



Turn-Key Solution

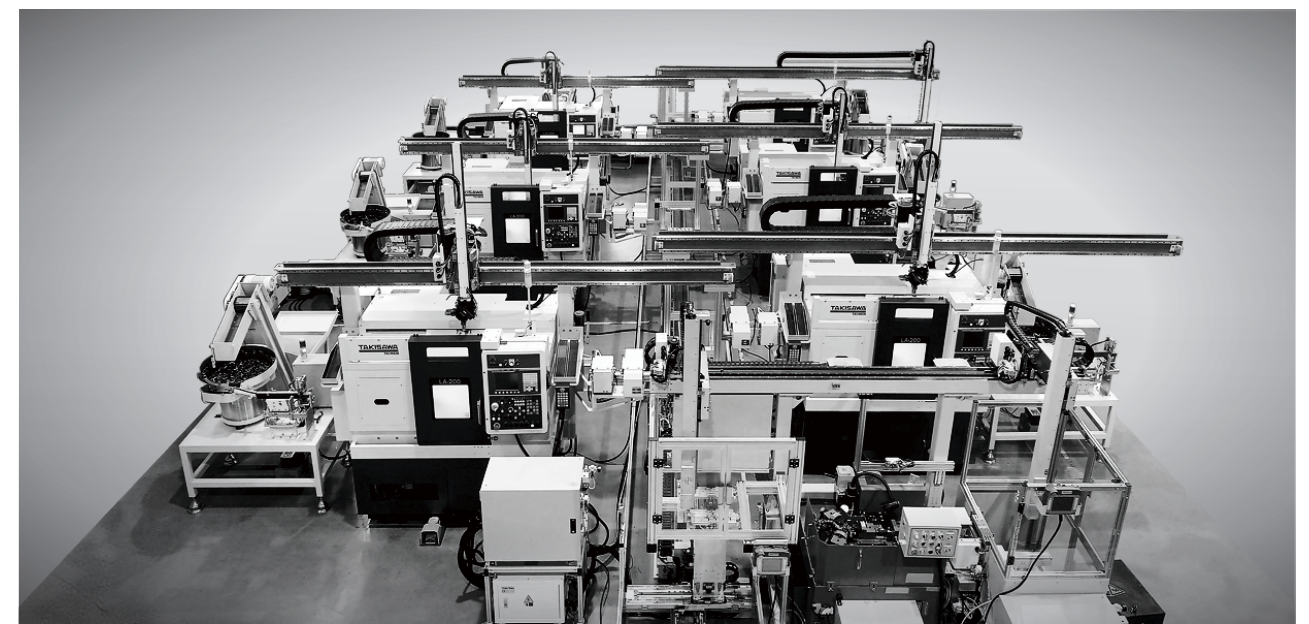

NC Unit Specifications

Specifications · Contents	LX-2500 LX-3000	LX-2500M LX-3000M	LX-2500Y LX-3000Y
Controller			
Oi-TF Plus	●	●	●
NC Unit			
10.4" Color LCD	●	●	●
15" Color LCD	◎	◎	◎
Safety Device			
Front Door Interlock	◎	◎	◎
Front Door Locking Mechanism	◎	◎	◎
Safety Relay	◎	◎	◎
Control Panel Breaker with Tripper	◎	◎	◎
Controlled Axes			
Least Input Increment (Linear Axis : 0.001mm, Rotary Axis: 0.001°)	●	●	●
Maximum Programmable Dimension (Linear Axis: ±99999.999mm, Rotary Axis: ±360°)	●	●	●
Arbitrary angular axis control	-	-	●
Least Input Increment C	▲	▲	▲
Inch/Metric Selection	●	●	●
Interlock	●	●	●
Machine Lock	◎	◎	◎
Emergency Stop	●	●	●
Stored Stroke Check 1	●	●	●
Stored Stroke Check 2, 3	●	●	●
Stroke Limit Check Before Movement	●	●	●
Chuck Tailstock Barrie	▲	▲	▲
Mirror Image (Each Axis)	▲	▲	▲
Chamfering ON / OFF	●	●	●
Overload Detection	●	●	●
Position Switch	●	●	●
Operation			
Auto Run (Memory)	●	●	●
MDI Run	●	●	●
DNC Run	●	●	●
DNC Run with Memory Card	●	●	●
Program Number Search	●	●	●
Sequence Number Search	●	●	●
Sequence Number Collation and Stop	●	●	●
Wrong Operation Preventive	▲	▲	▲
Buffer Register	●	●	●
Dry Run	●	●	●
Single Block	●	●	●
Jog Feed	●	●	●
Manual Reference Point Return	●	●	●
Dogless Reference Point Setting	●	●	●
Manual Handle Feed 2/3-units	●	●	●
Interpolating Functions			
Positioning (G00)	●	●	●
Exact Stop Mode (G61)	●	●	●
Tapping Mode (G63)	●	●	●
Cutting Mode (G64)	●	●	●
Exact Stop (G09)	●	●	●
Linear Interpolation (G01)	●	●	●
Circular Interpolation (G02/G03)	●	●	●
Dwell (G04)	●	●	●
Polar Coordinate Interpolation	-	●	●
Cylindrical Interpolation	-	●	●
Helical Interpolation	-	◎	●
Thread Cutting	●	●	●
Multiple Thread Cutting	●	●	●
Thread Cutting Cycle and Retraction	●	●	●
Continuous Thread Cutting	●	●	●
Variable Lead Thread Cutting	●	●	●
Reference Point Return (G28)	●	●	●

Specifications · Contents	LX-2500 LX-3000	LX-2500M LX-3000M	LX-2500Y LX-3000Y
Reference Point Return Check (G27)	●	●	●
2nd Reference Point Return (G30)	●	●	●
3rd, 4th Reference Point Return	●	●	●
Feed Function			
Rapid Traverse Override (F0, 25%, 50%, 100%)	●	●	●
Feed Per Minute	●	●	●
Feed Per Revolution	●	●	●
Constant Tangential Speed Control	●	●	●
Cutting Feedrate Clamp	●	●	●
Automatic Acceleration / Deceleration	●	●	●
Rapid Traverse Bell-Shaped Accel / Decel	●	●	●
Linear Accel/Decel After Feedrate Interpolation	●	●	●
Feedrate Override (15 Steps)	●	●	●
Jog Override (15 Steps)	●	●	●
Override Cancel	●	●	●
Manual Feed Per Revolution	▲	▲	▲
Program Input			
Tape Code (EIA / ISO Auto Recognition)	●	●	●
Label Skip	●	●	●
Parity Check	●	●	●
Control In / Out	●	●	●
Optional Block Skip, 1 Piece	●	●	●
Optional Block Skip (2 to 9 Pieces)	⊕	⊕	⊕
Program Number 04 Digits	●	●	●
Program File Name 32 Characters	●	●	●
Sequence Number N5 Digits	-	-	-
Sequence Number N8 Digits	●	●	●
Absolute/Incremental Command	●	●	●
Decimal Point Input / Pocket Calculator Type Decimal Point Input	●	●	●
Diameter /Radius Programming (X-Axis)	●	●	●
Coordinate System Setting (G50)	●	●	●
Auto coordinate System Setting	●	●	●
Drawing Dimension Direct Input	●	●	●
G-Code System A	●	●	●
G-Code System B/C	▲	▲	▲
Chamfering / Corner R Programming	●	●	●
Programmable Data Input	●	●	●
Sub Program Call (10 Levels)	●	●	●
Custom Macro	●	●	●
Additional Custom Macro Common Variables	●	●	●
Single Canned Cycle	●	●	●
Combined Canned Cycle	●	●	●
Combined Canned Cycle II	●	●	●
Drilling Canned Cycle	●	●	●
Circular Interpolation by R programming	●	●	●
Macro Executor	●	●	●
Coordinate System Shift	●	●	●
Coordinate System Shift Direct Input	●	●	●
Miscellaneous Function / Spindle Functions			
M Function (M3 Digits)	●	●	●
Second Miscellaneous Function (B Function)	◎	◎	◎
Spindle Functions (S4 Digits)	●	●	●
Constant Surface Speed Control	●	●	●
Spindle Orientation	●	●	●
Rigid Tap (Spindle Center)	●	●	●
Rigid Tap (Rotary Tool)	-	●	●
Data I/O			
RS-232C Interface for 1 ch	●	●	●
Fast Data Server	⊕	⊕	⊕
External Message	●	●	●
External Workpiece Number Search	◎	◎	◎
Memory Card I/O	●	●	●

Specifications · Contents	LX-2500 LX-3000	LX-2500M LX-3000M	LX-2500Y LX-3000Y
Tool Functions / Tool Offset Functions			
T Function (T2 + 2 Digits)	●	●	●
Tool Offsets, 32 Pieces	-	-	-
Tool Offsets, 64 Pieces	-	-	-
Tool Offsets, 128 Pieces	●	●	●
Tool Offsets, 200 Pieces	◎	◎	◎
Tool Offsets, 400 Pieces	-	-	-
Tool Geometry Size Data, 128 Pieces	●	●	●
Tool Position Offset	●	●	●
Tool Diameter / Nose R Compensation	●	●	●
Tool Geometry / Wear Compensation	●	●	●
Tool Offset Counter Input	●	●	●
Tool Offset Measured Value Direct Input	●	●	●
Tool Offset Measured Value Direct Input B	◎	◎	◎
Tool Life Management	●	●	●
Accuracy Offset Functions			
Backlash Compensation	●	●	●
Backlash Compensation by Rapid Traverse / Feedrate	●	●	●
Editing			
Part Program Memory Capacity 128Kbyte (320m)	-	-	-
Part Program Memory Capacity 320Kbyte (800m)	-	-	-
Part Program Memory Capacity 512Kbyte (1280m)	-	-	-
Part Program Memory Capacity 1Mbyte	-	-	-
Part Program Memory Capacity 2Mbyte	●	●	●
Registrable Programs, 63 Programs	-	-	-
Registrable Programs, 400 Programs	-	-	-
Registrable Programs, 1000 Programs	●	●	●
Program Editing	●	●	●
Program Protection	●	●	●
Extended Program Editing	●	●	●
Background Editing	●	●	●

Specifications · Contents	LX-2500 LX-3000	LX-2500M LX-3000M	LX-2500Y LX-3000Y
Setting / Display			
Status Display	●	●	●
Clock Function	●	●	●
Current Position Display	●	●	●
Program Comment Display (31 Characters)	●	●	●
Parameter Setting and Display	●	●	●
Alarm Display	●	●	●
Alarm Log Display	●	●	●
Operator Message Log Display	●	●	●
Operation Message Log Display	●	●	●
Run Hours and Parts Count Display	●	●	●
Actual Speed Display	●	●	●
Actual Spindle Speed and T Code Display	●	●	●
Floppy Cassette Directory Display	●	●	●
Optional Path Name Display	●	●	●
Servo Adjustment Screen	●	●	●
Maintenance Information Screen	●	●	●
Data Protection Key, 1 Kind	●	●	●
Help Function	●	●	●
Self Diagnostic Function	●	●	●
Scheduled Maintenance Screen	●	●	●
Hardware & Software System Configuration Display	●	●	●
Graphic Display	●	●	●
Dynamic Graphic Display	◎	◎	◎
Display Languages			
English	●	●	●
Japanese (Kanji)	▲	▲	▲
Other Language	▲	▲	▲
Display Language Dynamic Switching	●	●	●

● Standard ◎ Optional ⊕ Special
▲ Parameter setting is required - None

Smart Work Manager (Option)

O1

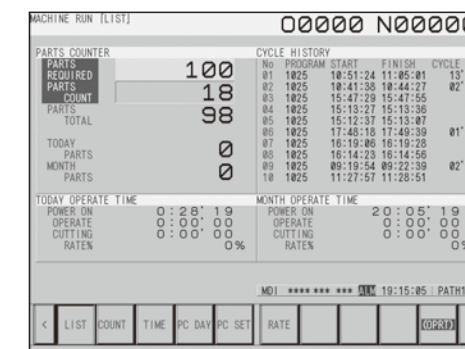

O2

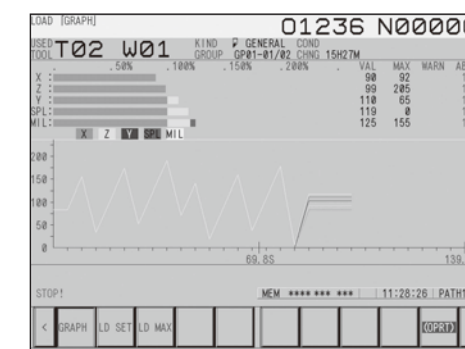

It provides simple operation and convenient function.

O1 Tool Life Manager

This function can set tool life and wear limit to manage all tools.

O2 Load Monitor

Detecting max load to check tool status.

O3 Parts and Machine Manager

It offers parts counter, program history, operate time for today or this month.

O3

