



More

[www.takisawa.com.tw](http://www.takisawa.com.tw)

Taiwan TAKISAWA Technology Co., Ltd.

No.505, Sec. 3, Yenping Rd., Pingchen Dist.,  
Taoyuan City 324, Taiwan.

TEL : +886-3-4643166 FAX : +886-3-4642614

No.89, Sec. 1, Meishi Rd., Yangmei Dist.,  
Taoyuan City 326, Taiwan.

TEL : +886-3-4813119 FAX : +886-3-4813185

E-mail : [callcenter@takisawa.com.tw](mailto:callcenter@takisawa.com.tw)

Shanghai TAKISAWA Mechatronics Ltd.

No.1568, Yuanguo Road, Anting Town, Jiading  
District, Shanghai

TEL : +86-21-59562955 FAX : +86-21-59562956

**TAKISAWA**<sup>®</sup>  
T A I W A N

Distributor

**NEX**

**NEX-108M  
NEX-108Y  
NEX-110M  
NEX-110Y**



**CNC  
LATHE**

03



NEX-108M | NEX-108Y  
NEX-110M | NEX-110Y

06



Spindle output diagram

08



Machine dimensions  
Working ranges  
Interference diagrams

15



NC unit specifications

11



Tooling system

12



Specifications

13



Standard and optional  
accessories

06



Spindle specifications



07



Turret specifications



# NEX-108M | NEX-108Y NEX-110M | NEX-110Y

1. Modulized structure with optional C and Y axis.
2. The Takisawa in-house turret and spindle features high rigidity and accuracy with easy maintenance.
3. Minimum footprint, maximum working space.
4. High productivity to investment cost ratio.



## Specifications

### NEX-108M

Max. swing	480 mm
Max. turning length	446.8 mm
Max. turning diameter	260 mm
Max. bar work capacity	52 mm
Spindle speed	4000 rpm
Chuck size	8"

### NEX-108Y

Max. swing	480 mm
Max. turning length	444.5 mm
Max. turning diameter	260 mm
Max. bar work capacity	52 mm
Spindle speed	4000 rpm
Chuck size	8"

※ Specifications are subject to change without notice.



## Specifications

### NEX-110M

Max. swing	560 mm
Max. turning length	629.8 mm
Max. turning diameter	350 mm
Max. bar work capacity	75 mm
Spindle speed	3500 rpm
Chuck size	10"

### NEX-110Y

Max. swing	560 mm
Max. turning length	635 mm
Max. turning diameter	350 mm
Max. bar work capacity	75 mm
Spindle speed	3500 rpm
Chuck size	10"

※ Specifications are subject to change without notice.



NEX-108M/NEX-108Y  
NEX-110M/NEX-110Y



# NEX-108M | NEX-108Y | NEX-110M | NEX-110Y



The NEX series can be tailored for greatly improved productivity by incorporating a gantry loading arm for loading and unloading and an automated feeding system for raw materials and finished components.

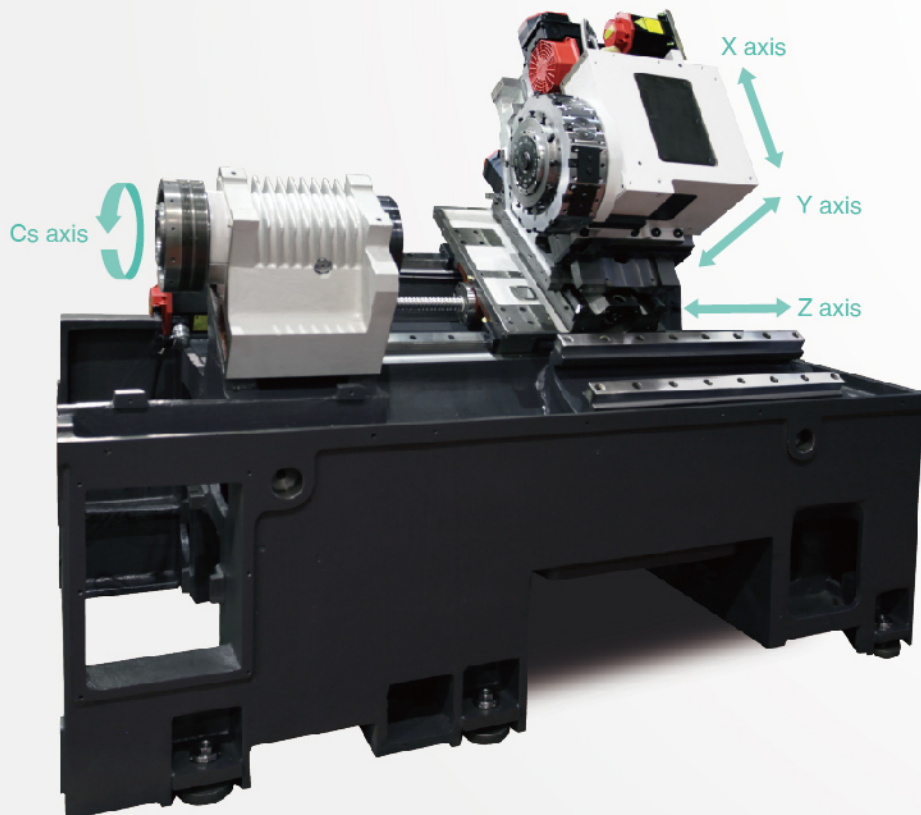
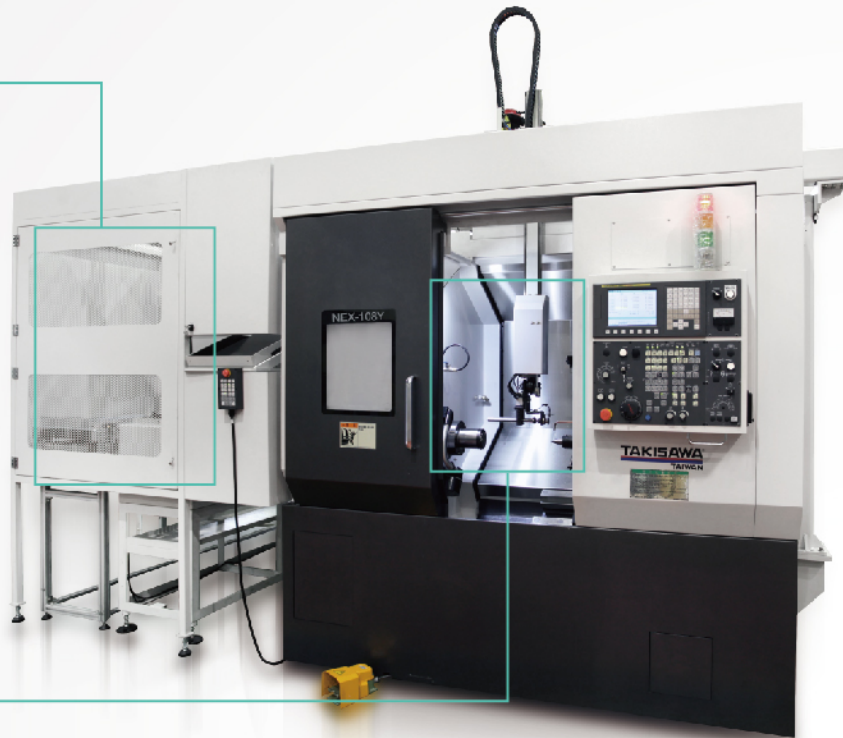

## Travel & Feedrate

NEX-108M / NEX-108Y	
X axis travel	180 / 195 mm
X axis rapid traverse rate	20 m/min
Z axis travel	530 mm
Z axis rapid traverse rate	24 m/min
Y axis travel	-- / ±40 mm
Y axis rapid traverse rate	-- / 10 m/min

NEX-110M / NEX-110Y	
X axis travel	220 mm
X axis rapid traverse rate	20 m/min
Z axis travel	710 mm
Z axis rapid traverse rate	20 m/min
Y axis travel	-- / ±50 mm
Y axis rapid traverse rate	-- / 10 m/min



# Spindle specifications

The spindle incorporates double rows of cylindrical bearings to improve the quality and accuracy of machining. Different chucks can be fitted to suit the machining of particular components.

NEX-108M/108Y Spindle nose : A2-6  
NEX-110M/110Y Spindle nose : A2-8

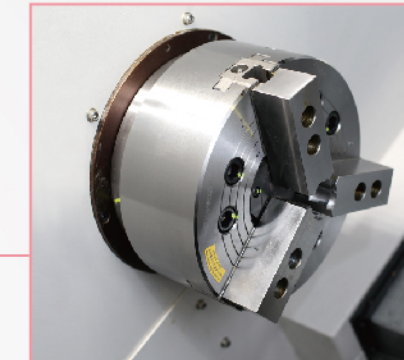
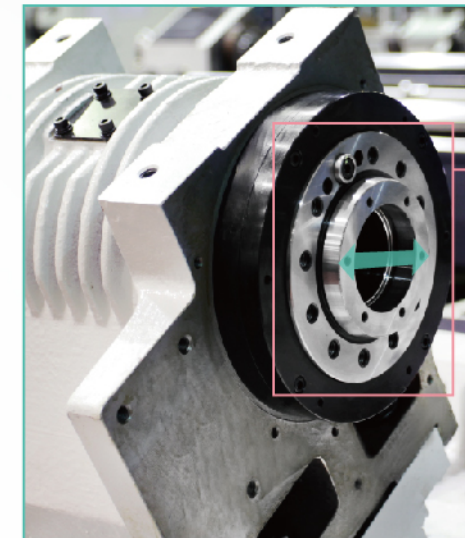

3 Jaw through-hole power chuck(Std.)

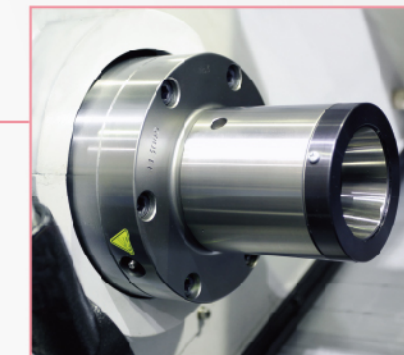

Collet chucks(OP)

NEX-108M/NEX-108Y  
NEX-110M/NEX-110Y



# Spindle output diagram

Powered by FANUC MOTOR for high stability & high accuracy.

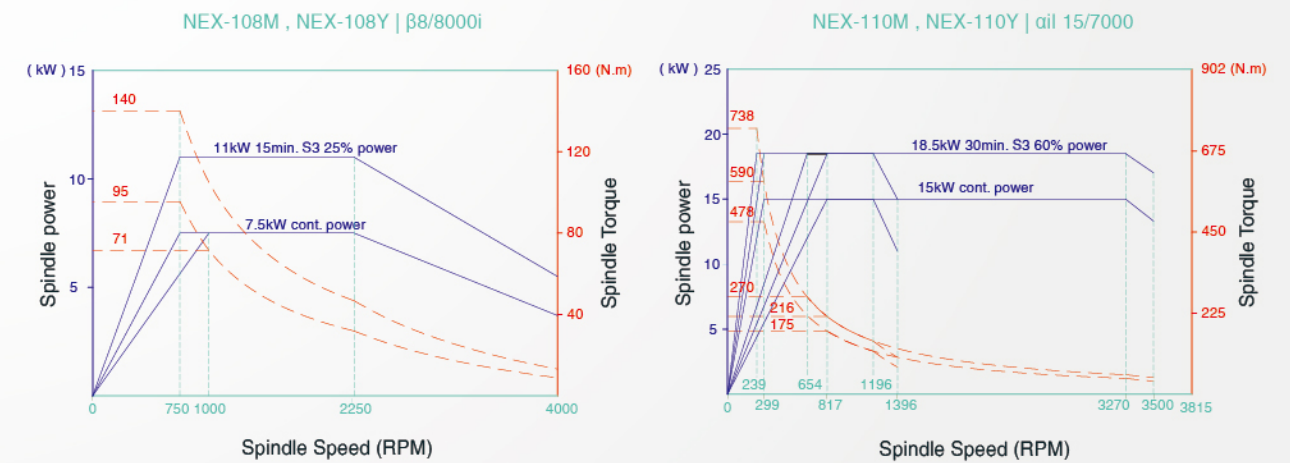



## Turret specifications

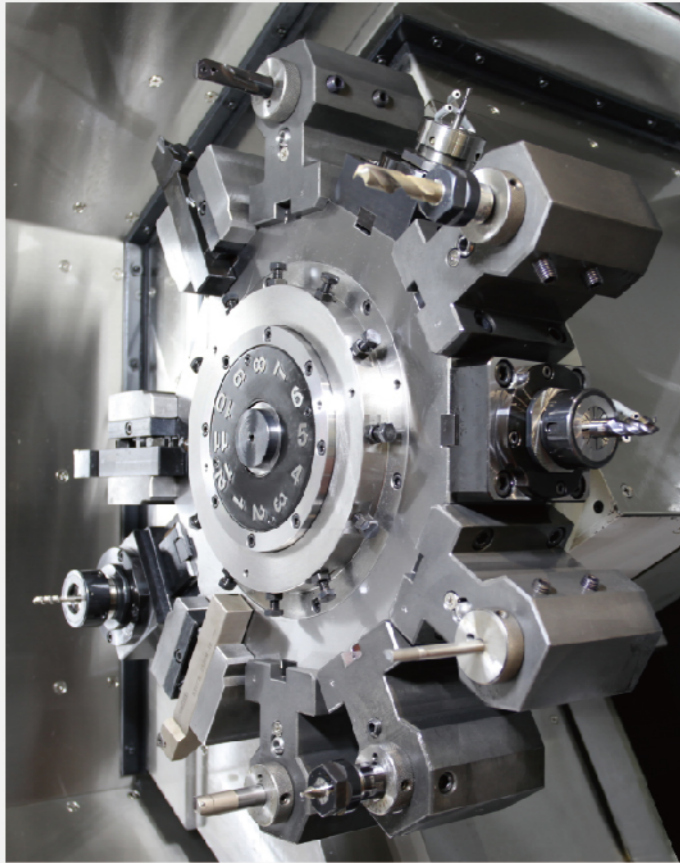

The turret is designed for extreme rigidity through its wide and heavy build, inclusion of heavy duty oversized couplings and enhanced clamping pressure.



## Power chart of milling tool

NEX-108M / NEX-108Y / NEX-110M / NEX-110Y

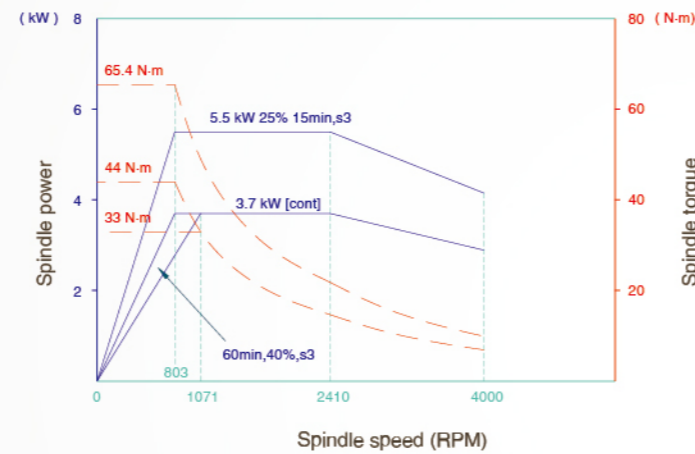

## Machining performance - NEX-108Y( $\beta$ il 8/8000)

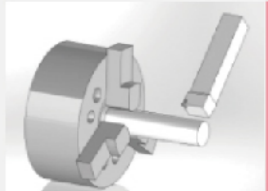

### O.D. heavy cutting

Tool ————— 25\*25 mm  
 Spindle speed ————— 1500 rpm  
 Cutting feedrate ————— 185 m/min

Cutting depth ————— 6 mm  
 Feed per rev. ————— 0.35 mm/rev

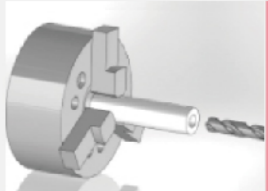

### Drill

Tool ————— Drill  
 O.D. drill ————— 22.5 mm  
 Spindle speed ————— 220 rpm

Cutting depth ————— 5 mm  
 Feed per rev. ————— 0.2 mm/rev

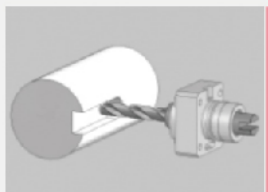

### Heavy milling

Tool ————— Milling  
 O.D. milling ————— 12 mm  
 Milling speed ————— 1300 rpm

Cutting depth ————— 12 mm  
 Feed per rev. ————— 0.2 mm/rev



## Machine dimensions

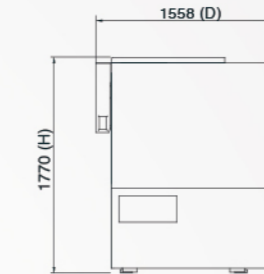
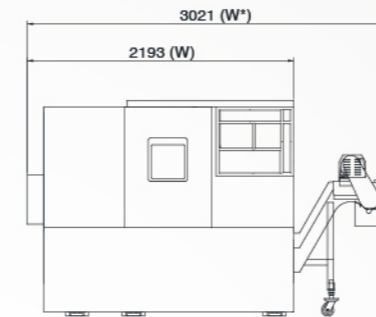

Width\* ————— 3021 mm  
 Width ————— 2193 mm  
 Height ————— 1770 mm  
 Depth ————— 1558 mm

NEX-108M

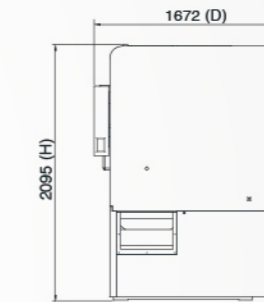
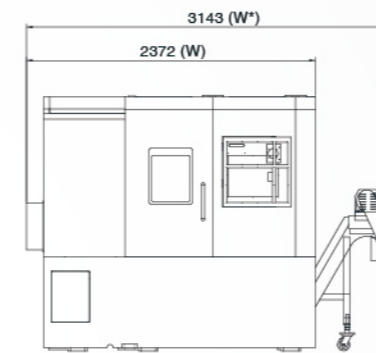

Width\* ————— 3143 mm  
 Width ————— 2372 mm  
 Height ————— 2095 mm  
 Depth ————— 1672 mm

NEX-108Y

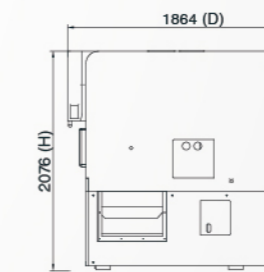
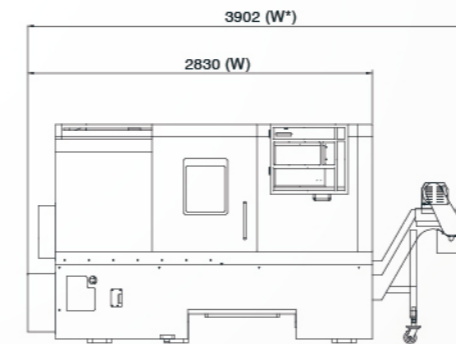

Width\* ————— 3902 mm  
 Width ————— 2830 mm  
 Height ————— 2076 mm  
 Depth ————— 1864 mm

NEX-110M

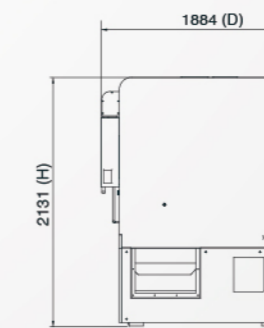
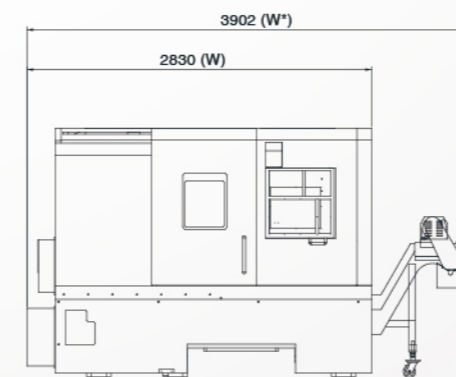

Width\* ————— 3902 mm  
 Width ————— 2830 mm  
 Height ————— 2131 mm  
 Depth ————— 1884 mm

NEX-110Y

NEX-108M/NEX-108Y  
NEX-110M/NEX-110Y



# Working range | Interference diagram

NEX-108M Working range

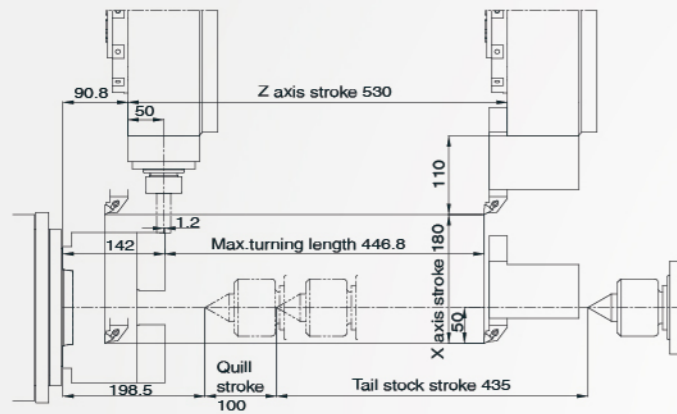

NEX-108M Interference diagram

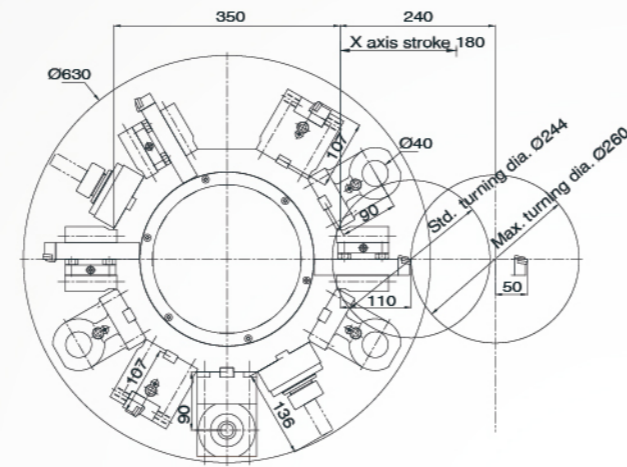

NEX-110M Working range

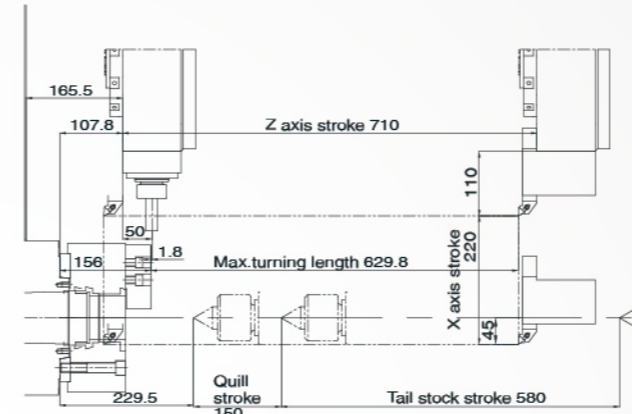

NEX-110M Interference diagram

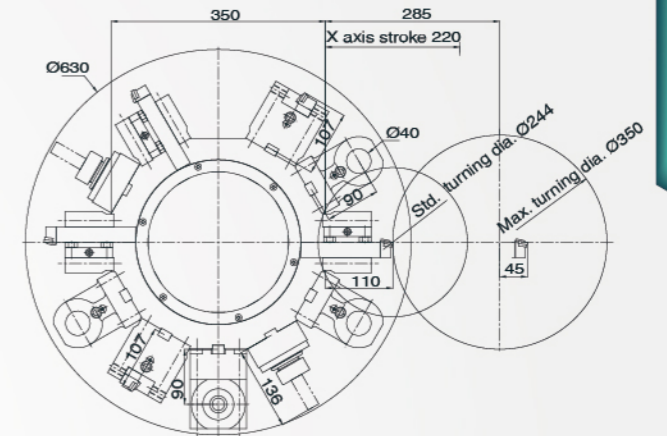

NEX-108Y Working range

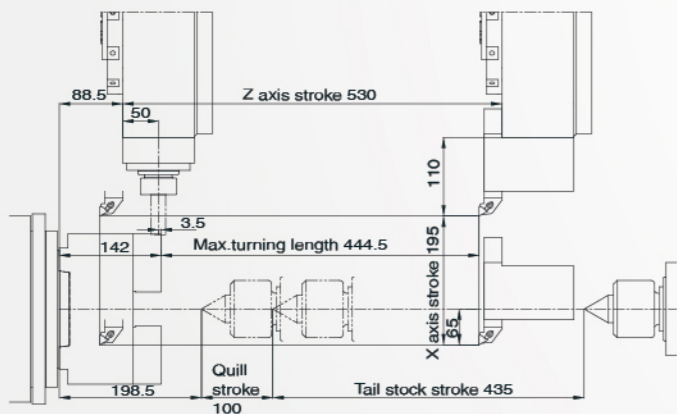

NEX-108Y Interference diagram

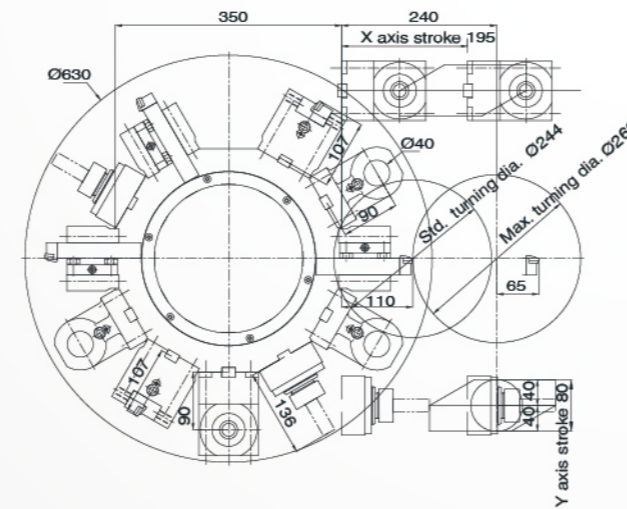

NEX-110Y Working range

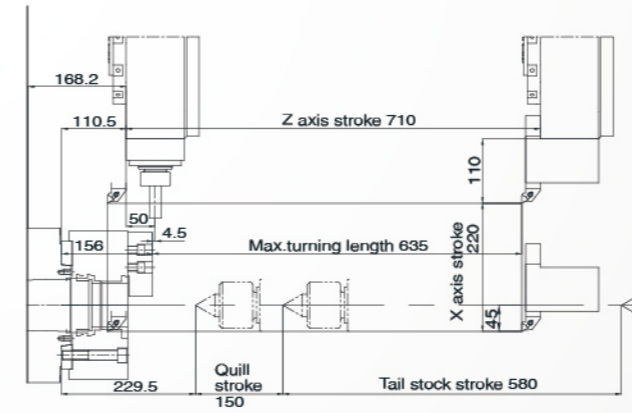

NEX-110Y Interference diagram

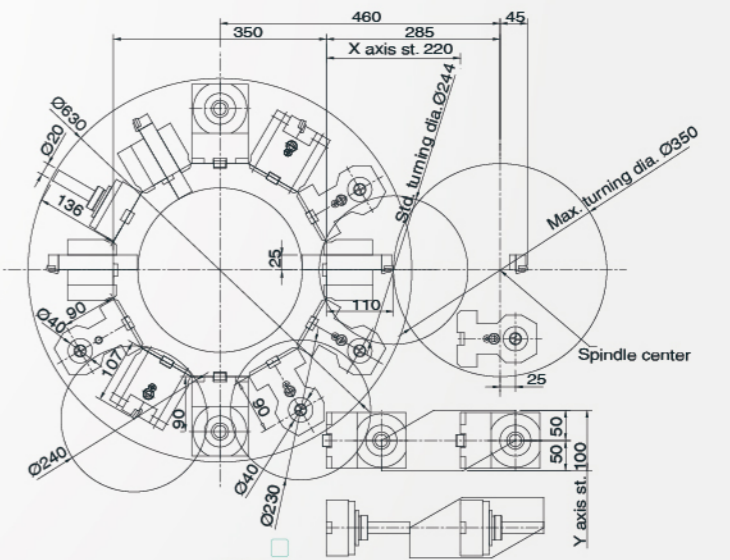

NEX-108M/NEX-108Y  
NEX-110M/NEX-110Y



# Tooling system

NEX-108M / NEX-108Y / NEX-110M / NEX-110Y

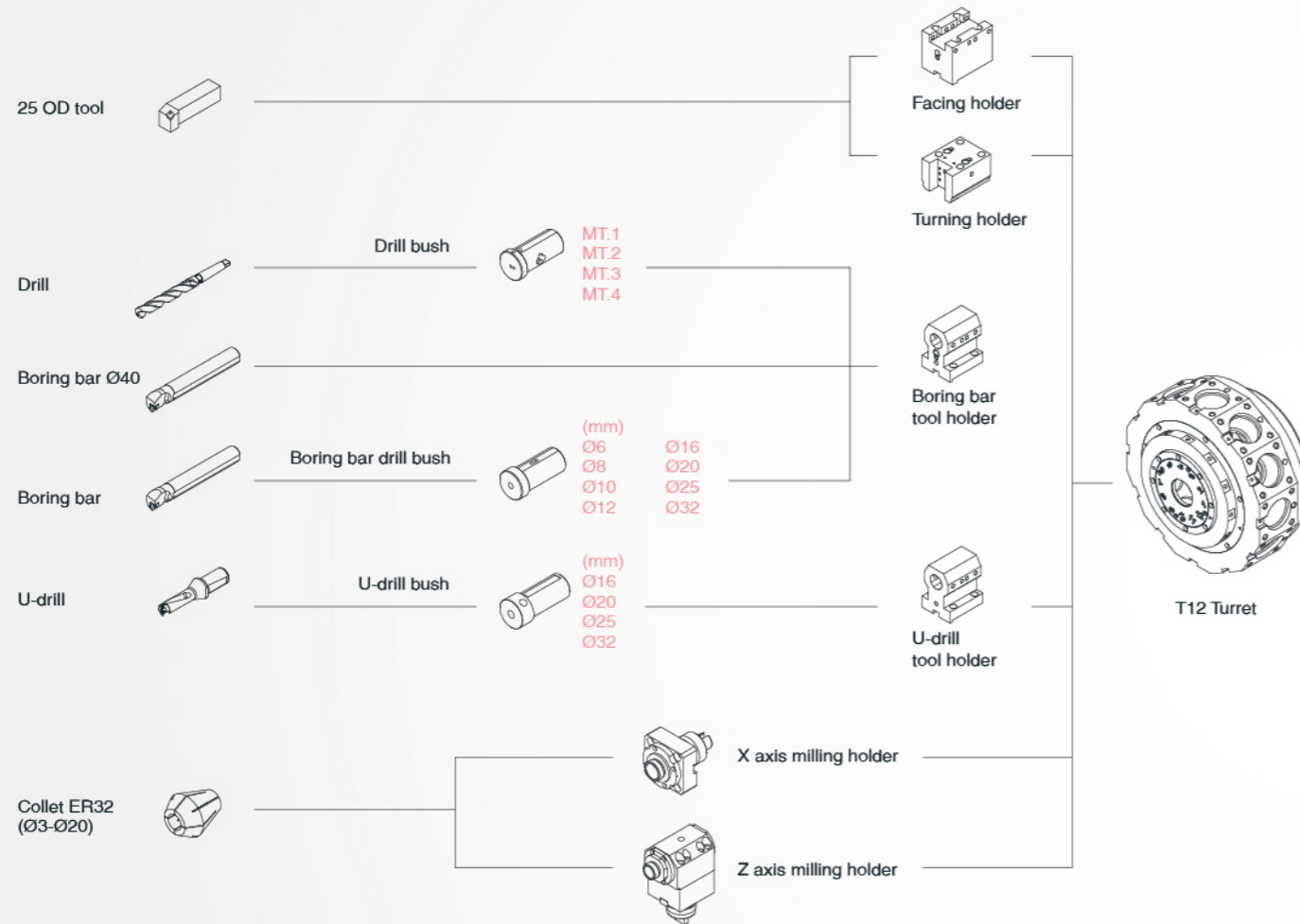

# Specifications

Remark : M = Milling Y = Y axis

Item	Unit	NEX-108M	NEX-108Y	NEX-110M	NEX-110Y
<b>Capacity</b>					
Max. swing	mm	480	480	560	560
Std. turning diameter	mm	244	244	244	244
Max. turning diameter	mm	260	260	350	350
Max. turning length	mm	446.8	444.5	629.8	635
Max. bar work capacity	mm	52	52	75	75
<b>Travel</b>					
X axis travel	mm	180	195	220	220
Z axis travel	mm	530	530	710	710
Y axis travel	mm	---	±40	---	±50
<b>Spindle</b>					
Spindle speed	rpm	4000	4000	3500	3500
Chuck size		8"	8"	10"	10"
Spindle nose		A2-6	A2-6	A2-8	A2-8
Through hole diameter	mm	63	63	86	86
Bearing diameter	mm	100	100	120	120
<b>Turret</b>					
Number of tools		T12	T12	T12	T12
Turning tool shank	mm	25	25	25	25
Boring bar shank diameter	mm	40	40	40	40
Milling tool shank diameter	mm	20	20	20	20
<b>Tailstock</b>					
Tailstock travel	mm	435	435	580	580
Tailstock spindle diameter	mm	75	75	110	110
Taper hole of tailstock spindle		MT.4	MT.5	MT.5	MT.5
Tailstock spindle travel	mm	100	100	150	150
<b>Feedrate</b>					
X axis rapid traverse rate	m/min	20	20	20	20
Z axis rapid traverse rate	m/min	24	24	20	20
Y axis rapid traverse rate	m/min	---	10	---	10
<b>Motor</b>					
Spindle drive motor	kW	7.5/11	7.5/11	15/18.5	15/18.5
Milling motor	kW	3.7/5.5	3.7/5.5	3.7/5.5	3.7/5.5
Turret index motor	kW	1.2	1.2	1.2	1.2
X axis drive motor	kW	1.2	2.5	1.2	2.5
Z axis drive motor	kW	2.5	2.5	2.5	2.5
Y axis drive motor	kW	---	2.5	---	2.5
<b>Size</b>					
Width	mm	2193	2372	2830	2830
Height	mm	1770	2095	2076	2131
Depth	mm	1558	1672	1864	1884
Weight	kg	4300	4500	6000	6500

※ Specifications are subject to change without notice.

NEX-108M/NEX-108Y  
NEX-110M/NEX-110Y



# Standard and optional accessories

※ Specifications are subject to change without notice.

☆ : Standard accessories --- : N/A ⊙ : Optional accessories

Item	NEX-108M	NEX-108Y	NEX-110M	NEX-110Y
<b>Accessories</b>				
Variable speed spindle	☆	☆	---	---
Hi-low Gearbox Spindle	---	---	☆	☆
Built in spindle motor	⊙	⊙	⊙	⊙
Hydraulic servo turret	☆	☆	☆	☆
Hydraulic tailstock	☆	☆	☆	☆
Manual tailstock base	☆	☆	---	---
Manual PIN tailstock base	☆	☆	☆	☆
Automatic PIN tailstock base	⊙	⊙	⊙	⊙
Boring bar tool holder (4PCS)	☆	☆	☆	☆
U-drill tool holder (1PCS)	☆	☆	☆	☆
Angle type tool holder (1PCS)	☆	☆	☆	☆
OD tool holder(1PCS)	☆	☆	☆	☆
Boring bar bush ø6 , ø8 , ø10 , ø12 , ø16 , ø20 , ø25 , ø32	☆	☆	☆	☆
U-drill bush ø16 , ø20 , ø25 , ø32	☆	☆	☆	☆
Drill bush MT.1 , MT.2 , MT.3 , MT.4	⊙	⊙	⊙	⊙
X axis live tool holder (1PCS)	☆	☆	☆	☆
Z axis live tool holder (1PCS)	☆	☆	☆	☆
Hanger (2PCS)	⊙	⊙	⊙	⊙
Leveling pad	☆	☆	☆	☆
Wedge	☆	☆	☆	☆
Working lamp	☆	☆	☆	☆
Tool box	☆	☆	☆	☆
Operation manual	☆	☆	☆	☆
Hydraulic chuck	☆	☆	☆	☆
Foot switch	☆	☆	☆	☆
<b>Optional accessories</b>				
Chip conveyor & chip cart	⊙	⊙	⊙	⊙
Tool setter	⊙	⊙	⊙	⊙
Parts catcher	⊙	⊙	⊙	⊙
Parts conveyor	⊙	⊙	⊙	⊙
Barfeeder & Interface	⊙	⊙	⊙	⊙
Air blow	⊙	⊙	⊙	⊙
Automatic Power-off	⊙	⊙	⊙	⊙
Parts counter	⊙	⊙	⊙	⊙
Collet chuck	⊙	⊙	⊙	⊙
Manual steady rest	---	---	⊙	⊙
Hydraulic steady rest	---	---	⊙	⊙
Rotating tail stock	---	---	⊙	⊙
Oil mist collector	⊙	⊙	⊙	⊙

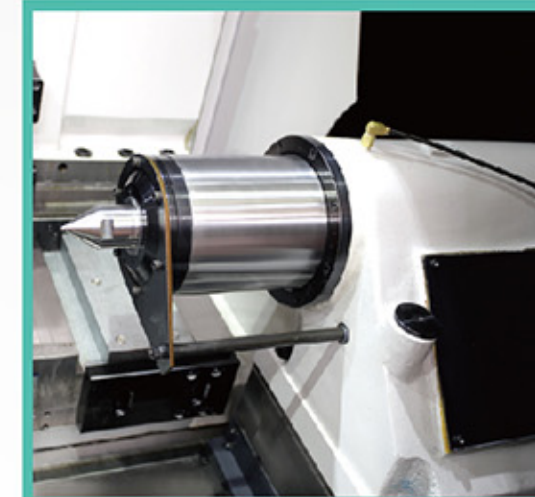

Rotating tail stock  
High thrust and clamping forces provide maximum stability especially when working with long workpieces.

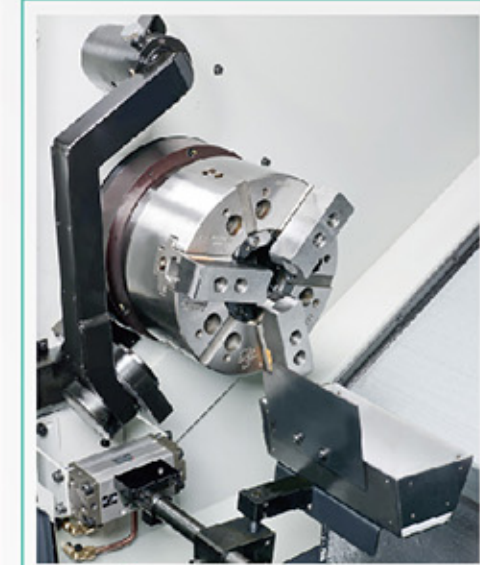

Parts catcher

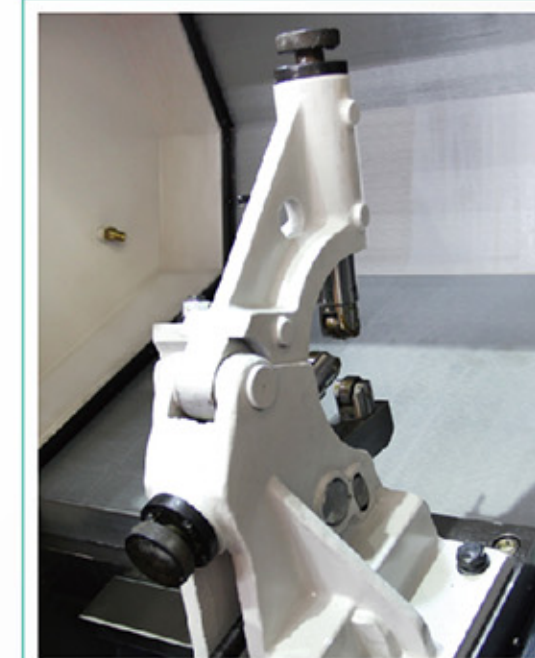

Manual steady rest

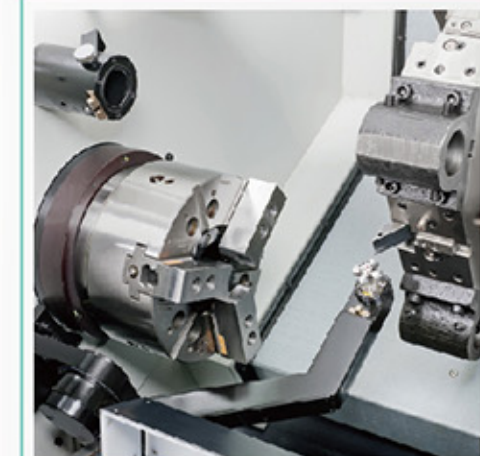

Tool setter

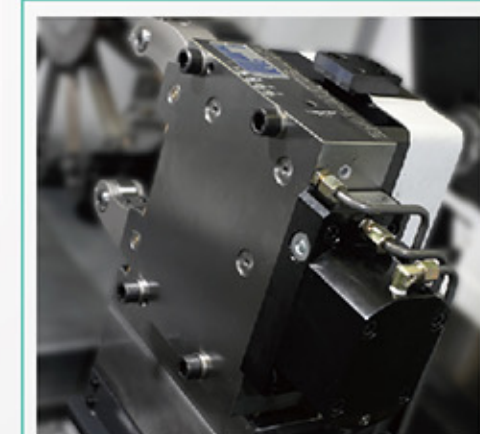

Hydraulic steady rest

NEX-108M/NEX-108Y  
NEX-110M/NEX-110Y





# NC unit specifications

## Composition

☆ : Standard    ◎ : Optional    ⊕ : Special    --- : N/A    △ : Parameter setting is required

Specifications / Contents	NEX-108M / 108Y / 110M / 110Y
<b>NC Unit</b>	
8.4" Color LCD	☆
10.4" Color LCD	◎
<b>Safety device</b>	
Front door interlock	◎
Front door locking mechanism	◎
Safety relay	◎
Control panel breaker with tripper	◎

## Main function list

☆ : Standard    ◎ : Optional    ⊕ : Special    --- : N/A    △ : Parameter setting is required

Specifications / Contents	NEX-108M / 108Y / 110M / 110Y
<b>Controlled axes</b>	
Least input increment	☆
Maximum programmable dimension(±999999.999)	☆
Least Input increment C	△
Inch/metric selection	☆
Interlock	☆
Machine lock	◎
Emergency stop	☆
Stored stroke check 1	☆
Stored stroke check 2,3	☆
Stroke limit check before movement	△
Chuck tailstock barrier	△
Mirror image (each axis)	△
Chamfering ON/OFF	⊕
Overload detection	◎
Position switch	⊕
<b>Operation</b>	
Auto run (memory)	☆
MDI run	☆
DNC run	⊕
DNC run with memory card	⊕
Program number search	☆
Sequence number search	☆
Sequence number collation and stop	☆
Wrong operation prevention	△
Buffer register	☆
Dry run	☆
Single block	☆
Jog feed	☆
Manual reference point return	☆
Dogless reference point setting	☆
Manual handle feed, 1 unit	☆

Specifications / Contents	NEX-108M / 108Y / 110M / 110Y
<b>Interpolating functions</b>	
Poitioning (G00)	☆
Exact stop mode (G61)	☆
Tapping mode (G63)	☆
Cutting mode (G64)	☆
Exact stop (G09)	☆
Linear interpolation (G01)	☆
Circular interpolation (G02/03)	☆
Dwell (G04)	☆
Polar coordinate interpolation	☆
Cylindrical interpolation	☆
Thread cutting	☆
Multiple thread cutting	☆
Thread cutting cycle and retraction	☆
Continuous thread cutting	☆
Variable lead thread cutting	☆
Reference point return (G28)	☆
Reference point return check (G27)	☆
2nd reference point return (G30)	☆
3rd, 4th reference point return	⊕
<b>Feed function</b>	
Rapid traverse override (F0,25%,50%,100%)	☆
Feed per minute	☆
Feed per revolution	☆
Constant tangential speed control	☆
Cutting feedrate clamp	☆
Automatic acceleration/deceleration	☆
Rapid traverse bell-shaped accel/decel	---
Linear accel/decel after feedrate interpolation	☆
Feedrate override (15 steps)	☆
Jog override (15 steps)	☆
Override cancel	☆
Manual feed per revolution	△
<b>Program input</b>	
Tape code (EIA/ISO auto recognition)	☆
Label skip	☆
Parity check	☆
Control in/out	☆
Optional block skip, 1 piece	☆
Optional block skip (2 to 9 pieces)	⊕
Program number O4 digits	☆
Program file name 32 characters	---
Sequence number N5 digits	☆

NEX-108M/NEX-108Y  
NEX-110M/NEX-110Y



# NC unit specifications

## Main function list

☆ : Standard    ◎ : Optional    ⊕ : Special    --- : N/A    △ : Parameter setting is required

Specifications / Contents	NEX-108M / 108Y / 110M / 110Y
<b>Program input</b>	
Sequence number N8 digits	---
Absolute/incremental command	☆
Decimal point input/Pocket calculator type decimal point input	☆
diameter /radius programming (X-axis)	☆
Auto coordinate /Coordinate system setting(G50)	☆
Drawing dimension direct input	△
G-code system A	☆
G-code system B/C	△
Chamfering/Corner R programming	☆
Programmable data input	☆
Sub program call (10 levels)	☆
Custom macro	☆
Additional custom macro common variables	☆
Single canned cycle	☆
Combined canned cycle I/II	☆
Drilling canned cycle	☆
Arc radius programming	☆
Macro executor	◎
Coordinate system shift/shift direct input	☆
<b>Miscellaneous function/spindle functions</b>	
M function (M3 digits)	☆
Second miscellaneous function (B function)	☆
Spindle functions (S4 digits)	☆
Constant surface speed control	☆
Spindle orientation	☆
Rigid tap (spindle center) /(rotary tool)	☆
<b>Tool functions/tool offset functions</b>	
T function (T2+2 digits)	☆
Tool offsets, 64 pieces	☆
Tool offsets, 99 pieces	◎
Tool offsets, 200/400 pieces	---
Tool geometry size data, 100 pieces	---
Tool position offset	☆
Tool diameter /nose R compensation	☆
Tool geometry /wear compensation	☆
Tool offset counter input	☆
Tool offset measured value direct input	☆
Tool offset measured value direct input B	◎
Tool life management	△
<b>Accuracy offset functions</b>	
Backlash compensation/by rapid traverse/feedrate	☆
<b>Editing</b>	

Specifications / Contents	NEX-108M / 108Y / 110M / 110Y
Part program memory capacity 128Kbyte (320m)	---
Part program memory capacity 320Kbyte (800m)	☆
Part program memory capacity 512Kbyte (1280m)	◎
Part program memory capacity 1Mbyte/2Mbyte	---
Registrable programs, 63 programs	---
Registrable programs, 400 programs	☆
Registrable programs, 1000 programs	---
Program editing/protection	☆
Extended program editing	☆
Background editing	☆
<b>Setting/display</b>	
Status display	☆
Clock function	☆
Current position display	☆
Program comment display (31 characters)	☆
Parameter setting and display	☆
Alarm display/Alarm log display	☆
Operator/ operation message log display	☆
Run hours and parts count display	☆
Actual speed display	☆
Actual spindle speed and T code display	☆
Floppy cassette directory display	☆
Grouped directory display and punching	☆
Servo adjustment screen	☆
Maintenance information screen	☆
Data protection key, 1 kind	☆
Help function	☆
Self diagnostic function	☆
Scheduled maintenance screen	☆
Hardware & software system configuration display	☆
Graphic display	☆
Dynamic graphic display	◎
<b>Display languages</b>	
English	☆
Japanese (Kanji)	△
Other language	△
Display language dynamic switching	☆
<b>Data I/O</b>	
RS-232C interface for 1 ch	☆
Fast data server	⊕
External message	☆
External workpiece number search	⊕
Memory card I/O	☆

NEX-108M/NEX-108Y  
NEX-110M/NEX-110Y