

SINCE 1944

* Specifications in this catalog are subject to change without prior notice.
* Please contact us or visit our site for more product information.

DL S series (24"~32")

Heavy duty CNC Turning Center (En)

DL 60L(M) / DL 70(M)

www.ffg-dmc.com



FFG DMC CO.,LTD.

631-821,86,Sandan 2-gil, Jinbuk-myeon, Masanhappo-gu,
Changwon-si, Gyeongsangnam-do, Korea

Phone : +82-(0)55-340-8200

Fax : +82-(0)55-340-8394

E-mail : sales@dmcmt.com

www.ffg-dmc.com



©FFG DMC 2017.11.09



DL S series (24"~32")

DL 60L(M)

DL 70(M)

High Rigidity, High Function Strong Heavy Cutting

Applied 2-step/3-step variable spindle,
confirmed wide-range constant output section,
Big Spindle Bore diameter[$\varnothing 181$, $\varnothing 320$ ($\varnothing 7.13$ ", $\varnothing 12.60$ ")]
to fit to machine oil pipeline.



DL 60L

Travel (X/Z) (mm)(inch)	470 x 3,270	18.50 x 128.74
Guideway Type	BOX Way	
Spindle speed (rpm)	1,400	
Number of tools (pcs)	12	



Front/Rear Chuck Available for Long Pipe Machining DL 70(M)

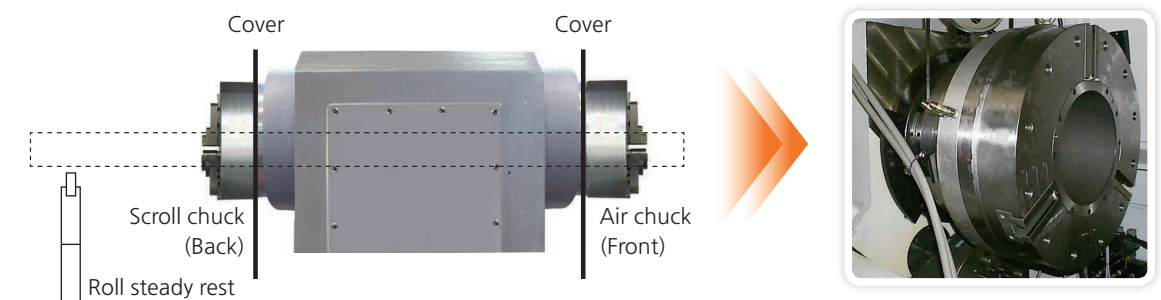

Unit : mm(inch)

Model	Spindle Bore diameter	Max. Turning Length	Max. Turning Dia.
DL 70(M)	320(12.60")	1,000(39.37")	900(35.43")
DL 60L(M)	181(7.13")	3,200(125.98")	900(35.43")

High Productivity

Spindle

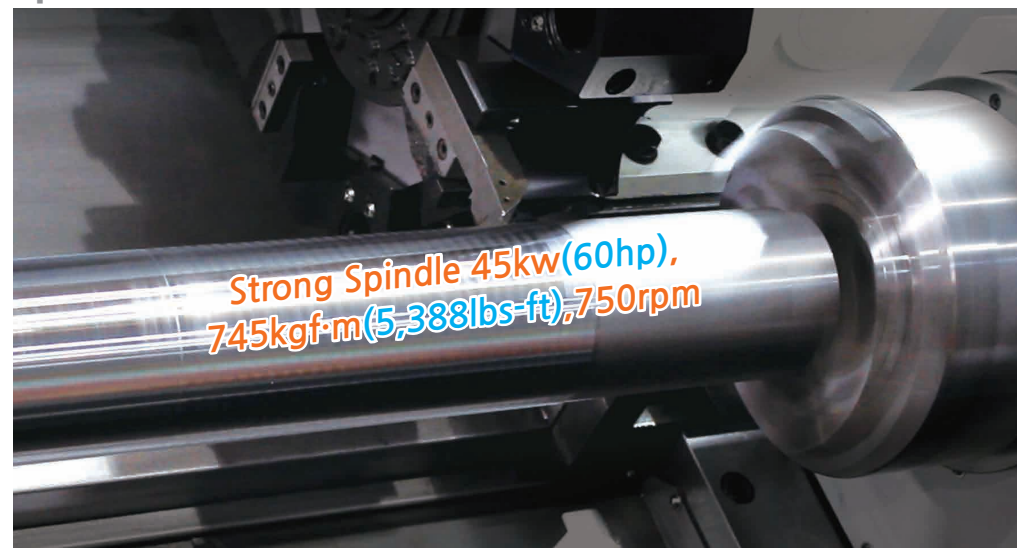

Heat radiating fan type headstock with minimum heat distortion

Heat radiation fan typed Rib structure minimizes headstock distortion by heat generation and prevents change of accuracy according to temperature increase.

	DL 60L(M)	DL 70(M)
Max. Spindle Speed (rpm)	1,400	750
Main Spindle Motor(kw/hp)	45(60)	45(60)
Max. Spindle Torque(kgf-m/lbs-ft)	503.1(3,639)	746.9(5,402)
Spindle Nose	A2-15	A2-20

DL 60L(M) : 1,400rpm

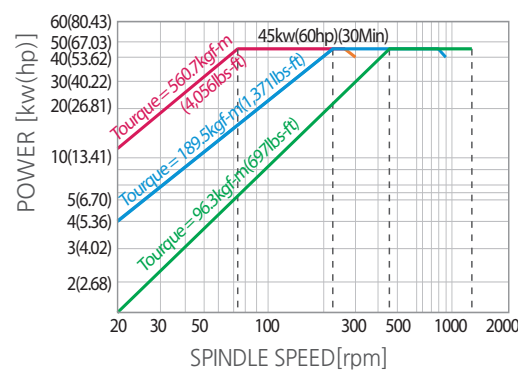

DL 70(M) : 750rpm

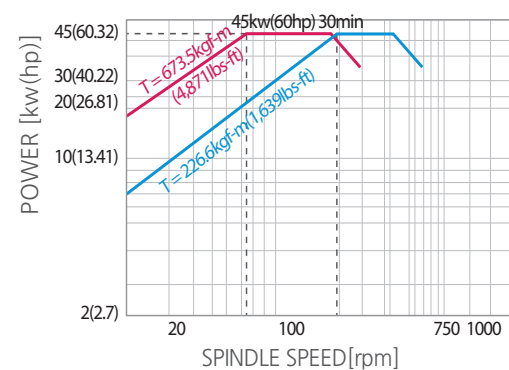

Spindle Bore diameter

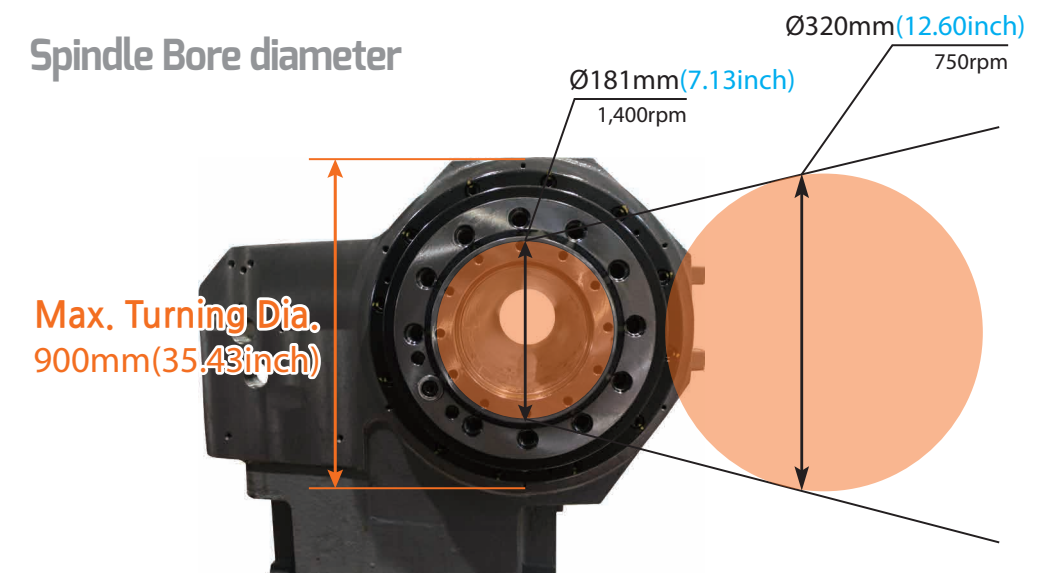

High torque adapted at low speed by shifting gear and could be selected several spindle bore dia. according to workpiece.

Spindle Bore diameter [Ø181mm, Ø320mm (Ø7.13inch, Ø12.60inch)]

Strong Gear Box

- Adopted high-precision gear box, the separated structure between mission and spindle motor, spindle reduce noise and vibration. Also, in high/low step excellent surfaced.

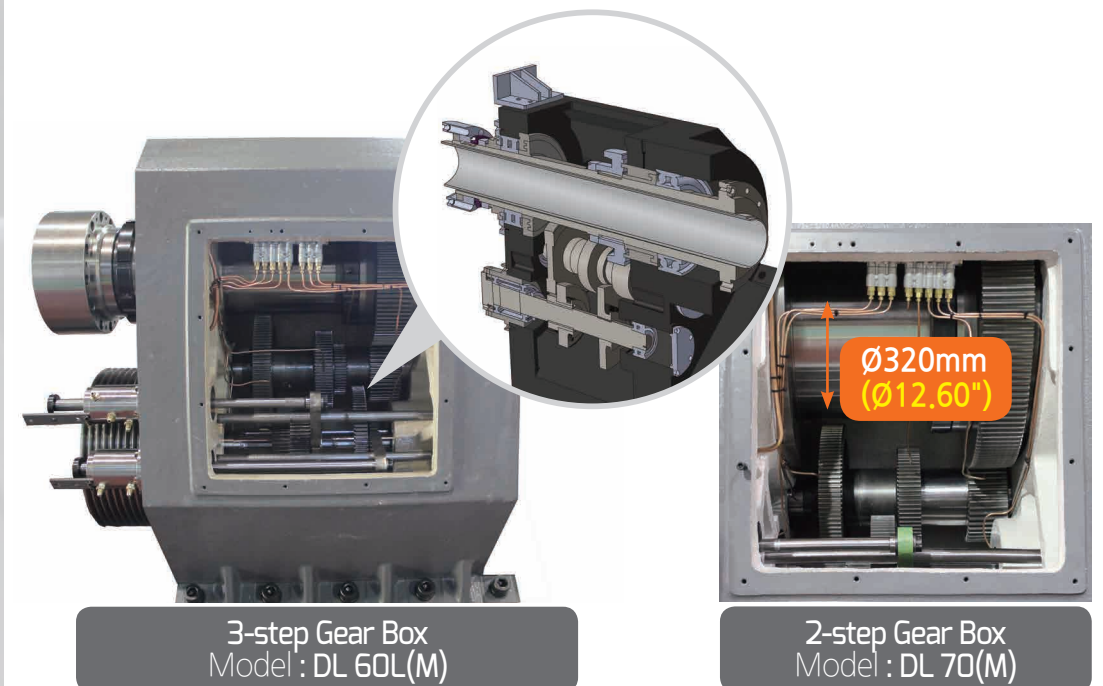

High Productivity

Turret

DL 60L/70 High Torque Servo Turret

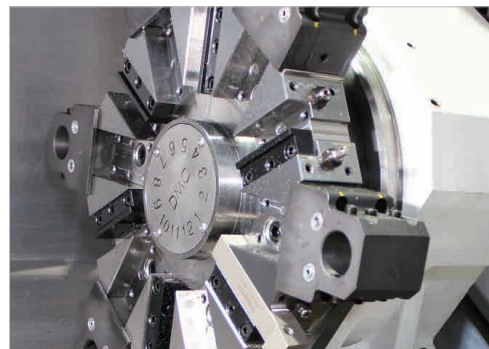

Turret Index Time
0.25 sec.

Max. No. of tools
12 stations

Standard Turret

- 3Piece curvic coupling : Prevent overhang while rotating
- Tool Size : □ 32mm, Ø80mm(□ 1.26", Ø3.15")
- Turret Clamping force [at 35kgf/cnt(497.82psi)] : 18,225kgf(40,179lbs)
- Turret indexing : [repeatability ± 0.005mm(0.0002")]

Big size turret with 12 tools possible for permanent tooling and available left or right tooling. High fast Index by high torque motor and 400 mm big diameter curvic coupling and 20 Ton force for high precision machining and heavy cutting.

Long Boring Bar Application

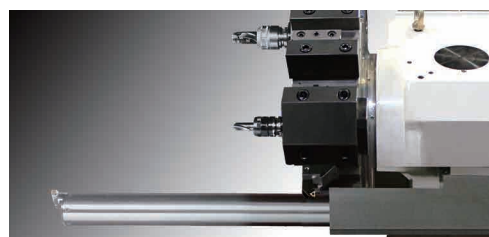

By mega long boring bar available for deep hole boring at one-time. (Where boring block fixed by bolt in turret body, it is not available to index)

DL 60LM/70M High Torque BMT Servo Turret

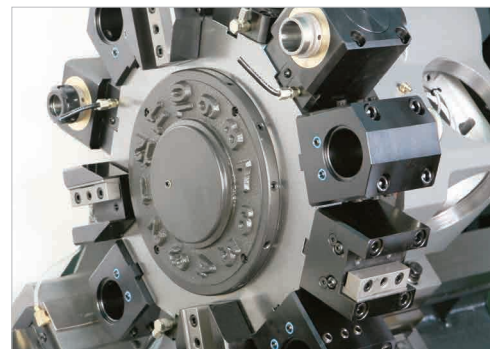

Mill Spindle max speed
3,000 rpm

Tool Holder
BMT 85

Mill Turret

- 3Piece curvic coupling : Prevent overhang while rotating
- Tool Size : □ 32mm, Ø80mm(□ 1.26", Ø3.15")
- Turret Clamping force [at 35kgf/cnt(497.82psi)] : 10,631kgf(23,437lbs)
- Turret indexing : [repeatability ± 0.005mm(0.0002")]

Rigid BMT Holder set by four bolt could make excellent performance in heavy cutting. Also, all directions like front/side and milling/drilling, tapping could be available.

Milling Turret Output Diagram

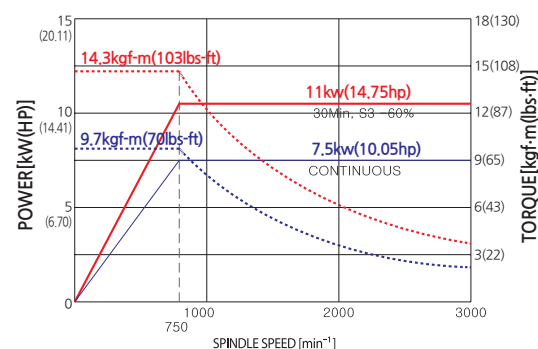

Tailstock

Programmable Tailstock

**Ø180mm(7.09") Quill dia.
150mm(5.91") Quill stroke**

Built-in tailstock(Applied spindle in sleeve) : MT#6 dead center type is more powerful and rigid than live center.

Tailstock Quill diameter	Ø180mm(7.09")
Tailstock Quill stroke	150mm(5.91")
Max. Thrust of Tailstock Quill	8,196kgf(18,069lbs)
Max. Hydraulic pressure	40kgf/cm ² (568.94psi)
Tailstock Quill taper	MT#6 (Built-In)

X/Z Axis

Pretension-applied Double Anchoring Ball Screw Supporting Structure

Optimal combination of triple angular ball bearing, double angular bearing and radial bearing for high rigidity and minimized heat distortion.

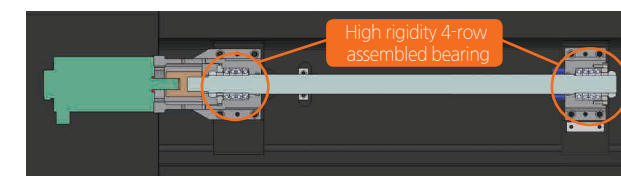

Items	DL 60L(M)	DL 70(M)
Travel(X/Z)(mm[inch])	470/3,270[18.50/128.74]	470/1,050[18.50/41.34]
Rapid traverse(m/min[ipm])	12/10[472.44/393.70]	12/18[472.44/708.66]

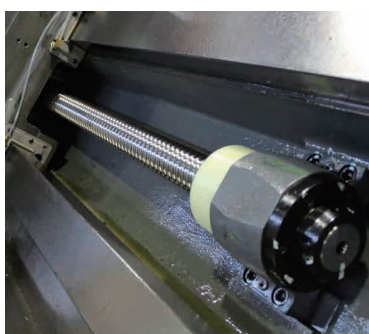

Hydraulic Steady Rest

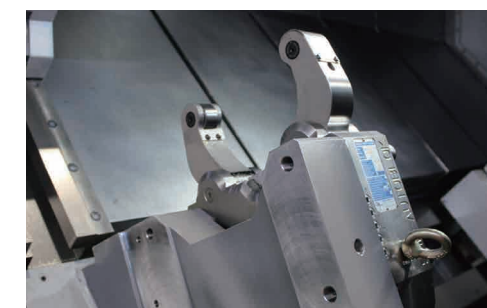

The hydraulic steady rest provides stable and accurate machining of long workpiece.

Model	Unit	Specifications
DL 60L(M)	mm (inch)	Ø50 ~ Ø310 (Ø1.97 ~ Ø12.20)
DL 70(M)	mm (inch)	Ø90~Ø350 (Ø3.54 ~ Ø13.78)

High Productivity

Bed

*Solid Structure,
fit to machine big material*

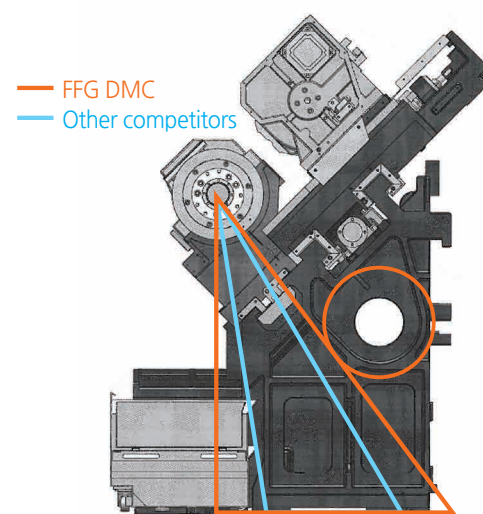
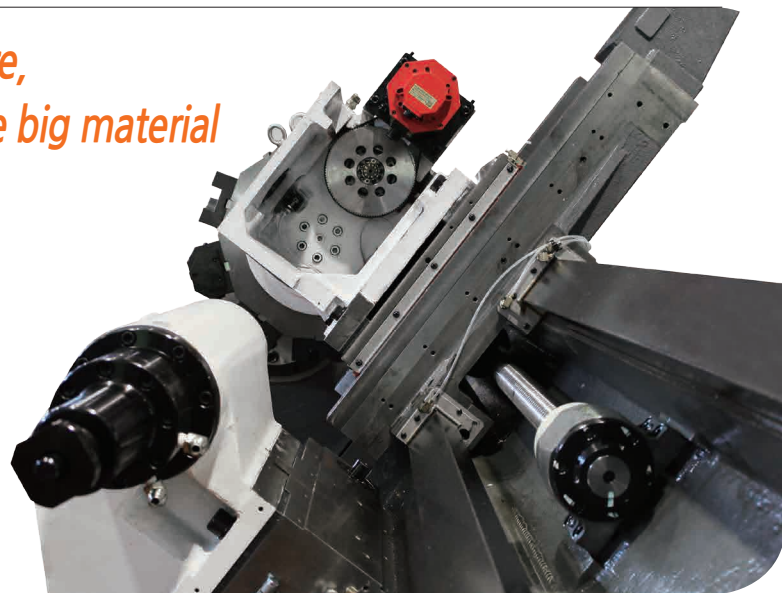

Highest precision even in intermittent cutting with great absorption ability

- 45 degree slant bed is great for vibration-dampening capability. High precision quality is guaranteed in a heavy duty cutting and enhanced machine life with elimination of distortion or deformation.

Offers Wide Bed Leveling

- Spindle overhang prevention (provides greater stability)
- **FFG DMC** : Right triangle
- **Other company** : Obtuse triangle
- Guaranteed stability against cutting resistance.
- Reduced vibration during high-speed rotation.
- Strong structure against any deformation in long-term.
- Protruding bed leveling boss ensures greater stability in performance.

Accuracy

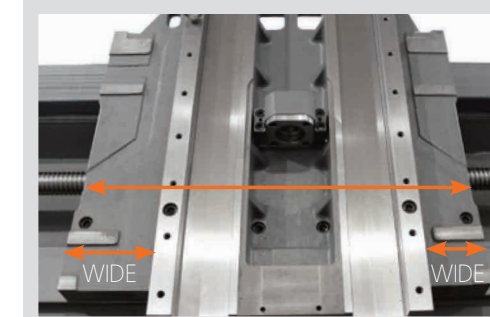

**WIDE SADDLE
Best Rigidity in Class**

- Expand Saddle Guideway's contact surface width, prevent the overhang of turret and machining vibration.
- Best High Rigidity in Class

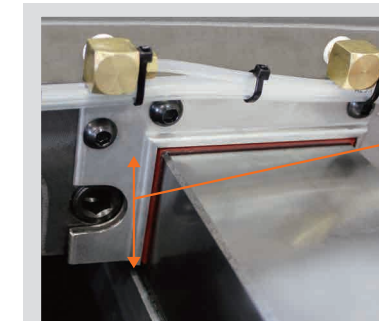

Box way

1.8x thicker than other competitors

- X,Z axis
- Wide inner 6-faces Slide way, after high frequency Heat Treatment, can be precision grinded so that keep high precision, strong cutting long-time. Hand scrapping on cast iron (Competitor's turcite)

Roundness

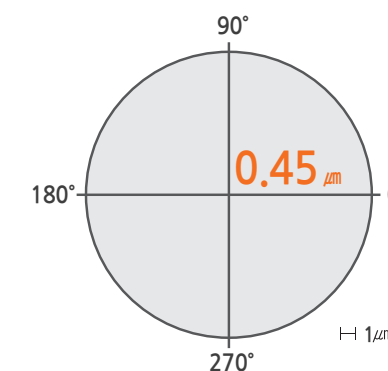

Example Of Machining

Turning Performance(material:SM45C) DL 60

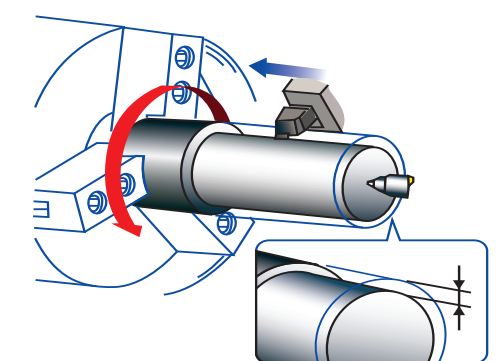

Surface Roughness(O.D. cutting)

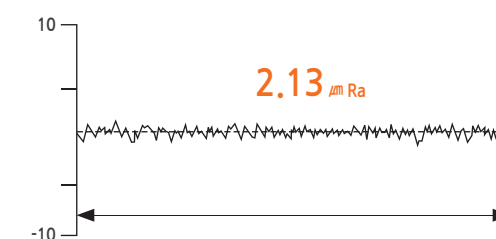

Heavy-duty cutting (O.D) <32mm×32mm qualified tool>

Spindle speed **367rpm**
 Cutting speed **150mm/min(5.91ipm)**
 Depth of cut **15mm(0.59")**
 <Spindle Load 65%>
 Feedrate **0.4mm/rev(0.016ipr)**

• This is actual cutting result. It might be not available under certain circumstances.

User-Friendly, Safe and Designed for Operator Efficiency / Ergonomics

2-Panel Safety Glass

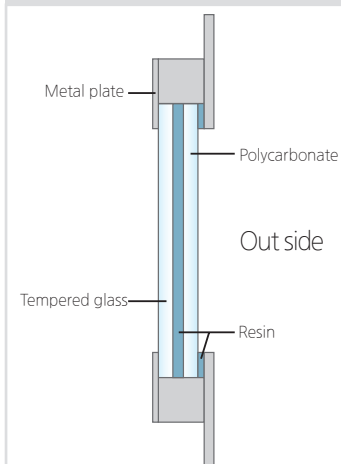

LED Working Light



+ Long-life LED lighting creates well lighted work environments.

Chuck open/close identification(STD.)

+ Chuck status is regularly checked for smooth operation

X-Link Slide Cover

+ Applied X-Link Slide Cover, minimized trouble and long-lasting life

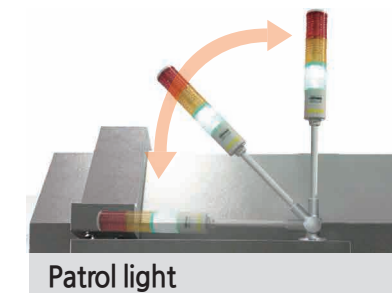

Patrol light

+ LED 3 color wrapped folded when shipping

Front Door Interlock Device

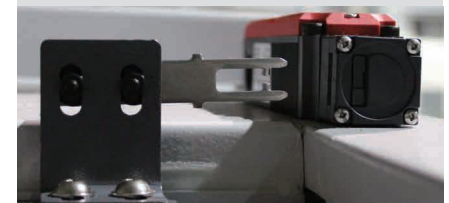

+ CE standard safety switch can sense door open and close; door is closed during operation

Spindle Load Meter Gauge

RS232C (Input/output interface)



+ USB port

Oil retrieval box



Oil leak prevention

+ Cover to ensure the pleasant work place.
+ Long-lasting life with wiper protection.



3 steps filter coolant tank Easy Clean-up & Prevent Coolant over flow

+ Chip conveyor installation - front/side type

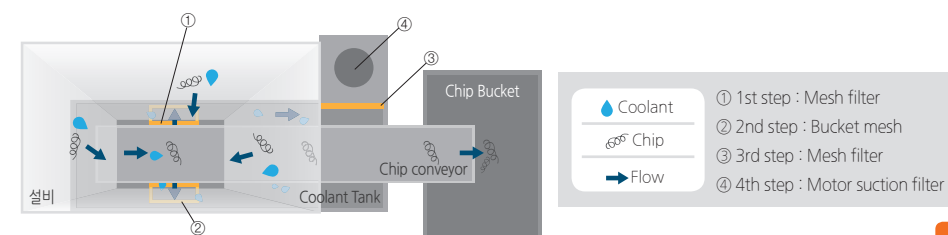

Option

Coolant gun

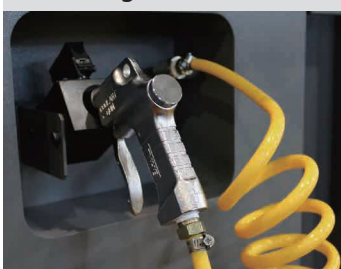

Air gun

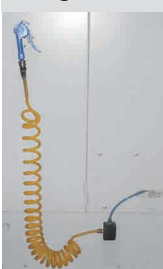

Nipple (air, coolant)

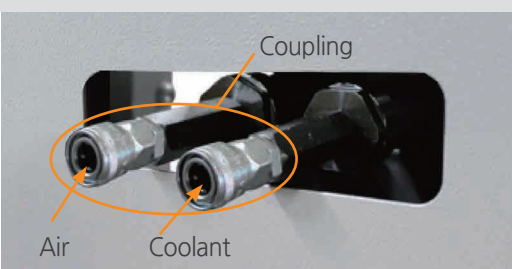

Easy Clean-up Removable Coolant Tank



+ Big size tank
+ Drawer-type oil tank with wheels is detachable from the coolant tank for easy daily maintenance.

Tool setter(OPT.)

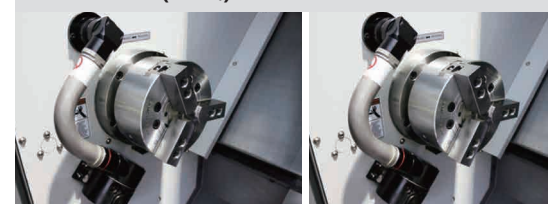

Manual

+ Manual Tool setter
+ Aluminum metallic tube, compact design

Automatic

+ Auto Tool setter
+ Fully authenticated components

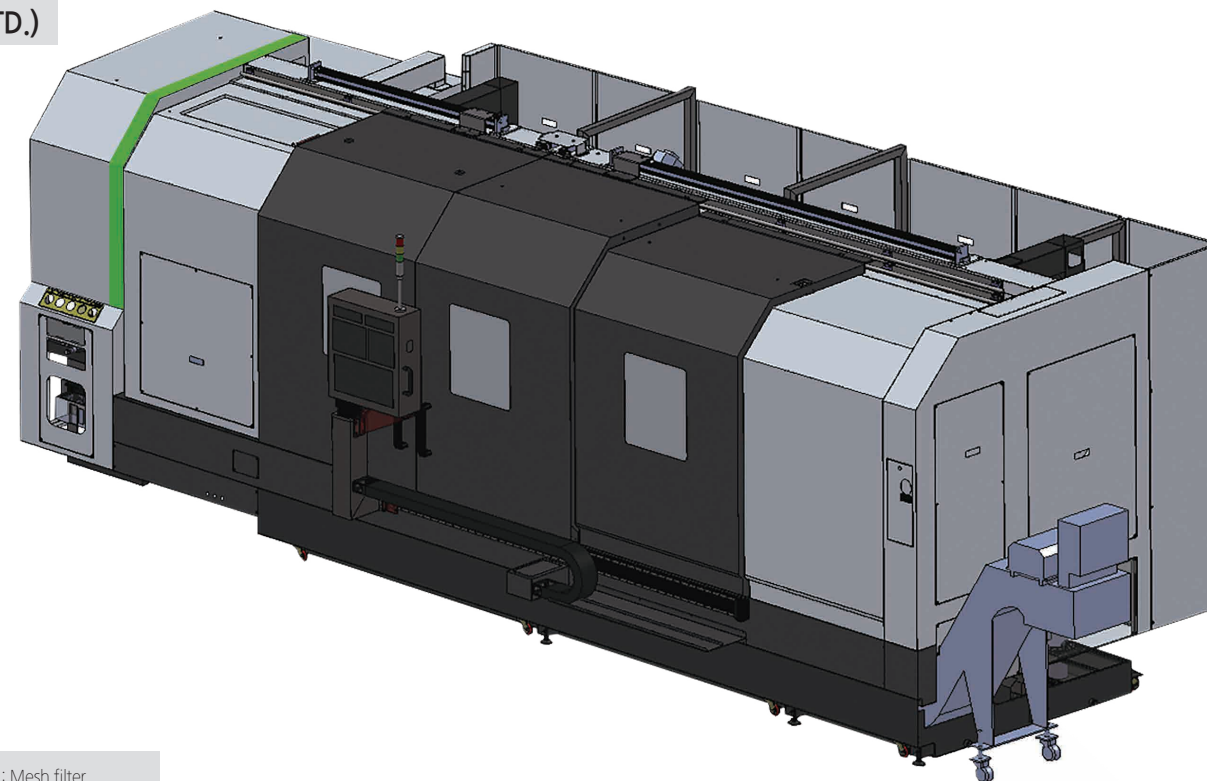

Lubrication unit (3ℓ/0.79gal)



+ Front assembled to be able to confirm by operator

Movable CNC panel



+ Convenient swiveling CNC panel

Option

Various standard options and Specialized features for customers

Features

Standard: Hydraulic chuck, Soft jaw, Tool box, Hydraulic unit, Door interlock, Cutting oil supplying device, Work light, Leveling bolt&place, Foot switch, Air unit, Lubrication unit, 3-step patrol light, Chuck open/close identification, RS232C

Option Equipment

Auto Front Door

Chip conveyor

Moderate/High pressure Coolant(6/20 bar)

Oil Mist Collector

Oil Skimmer(Belt type)

Oil Skimmer(Disk type)

Line Filter(100 Mesh)

Spindle thru Air/Coolant (when special chuck is included)

Multi Counter

Special Chuck

Upper side chuck Air/Coolant

230ℓ (60.76gal) (Swing)
300ℓ (79.25gal) (Swing)
300ℓ (79.25gal) (Fork lift)
380ℓ (100.38gal) (Fork lift)
440ℓ (116.23gal) (Fork lift)

Point sensor(Z/X)

Linear scale(High precision position control)

Sub control panel

Counter

Air Limit(Workpiece contact surface check equipment)

Other soft options selection

- I/O extension(16 contacts, 32 contacts)
- Automatic power-off
- M - code

Tooling system

□ : Option(Not-Supplied)

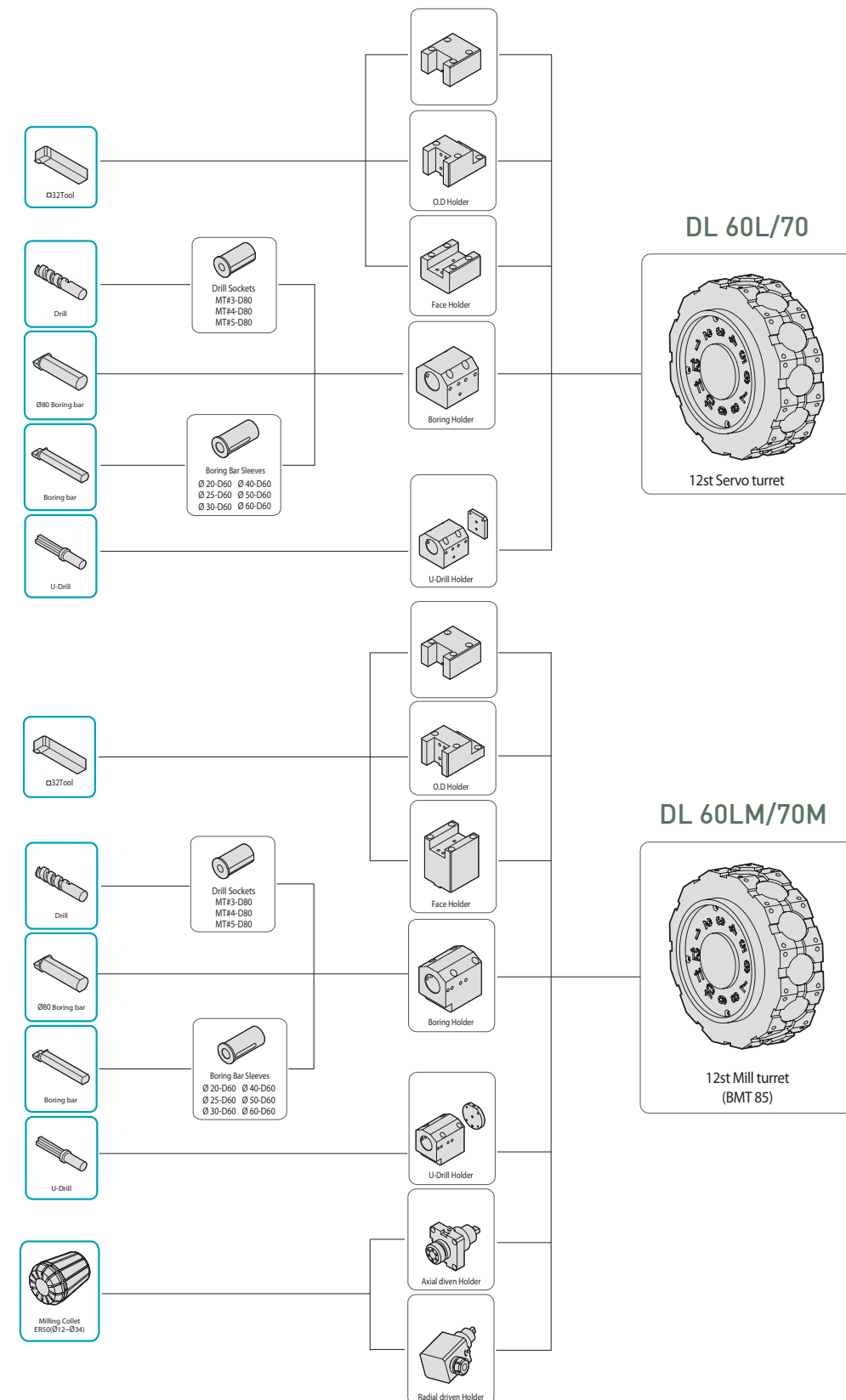

Tooling interference diagram

Unit : mm[inch]

DL 60L/70

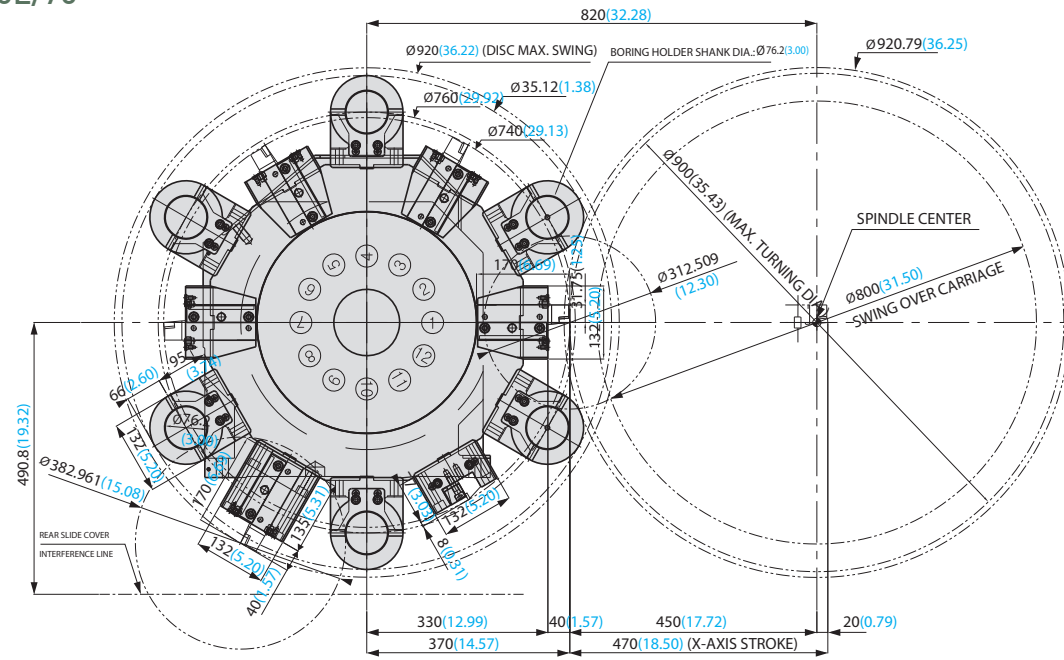

DL 60LM/70M

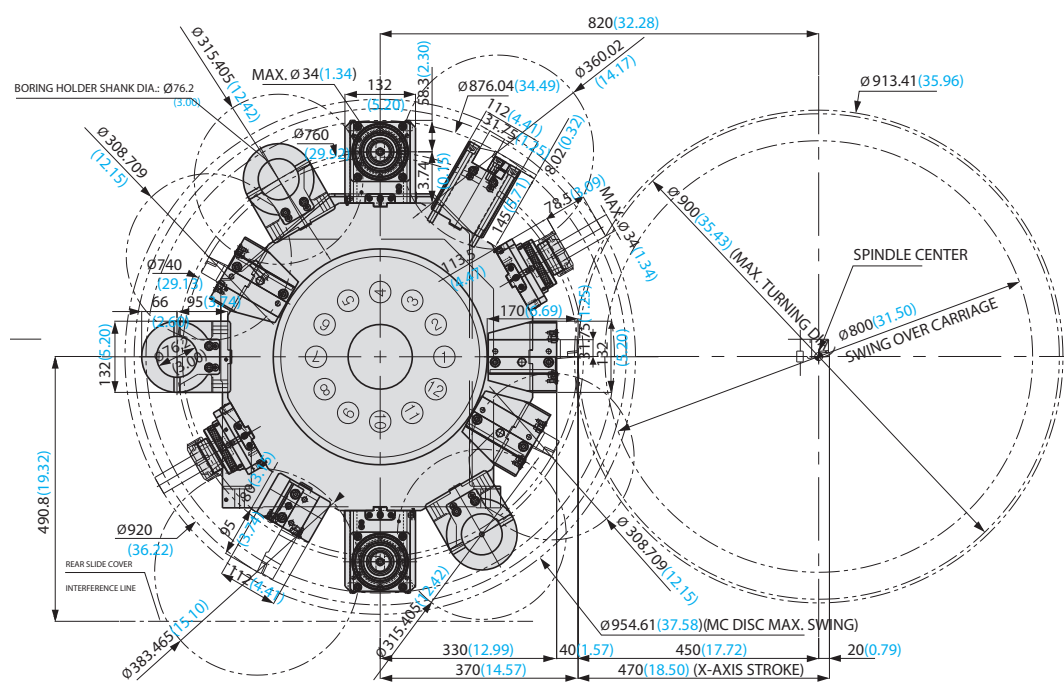

Working range

Unit : mm[inch]

DL 60L/60LM

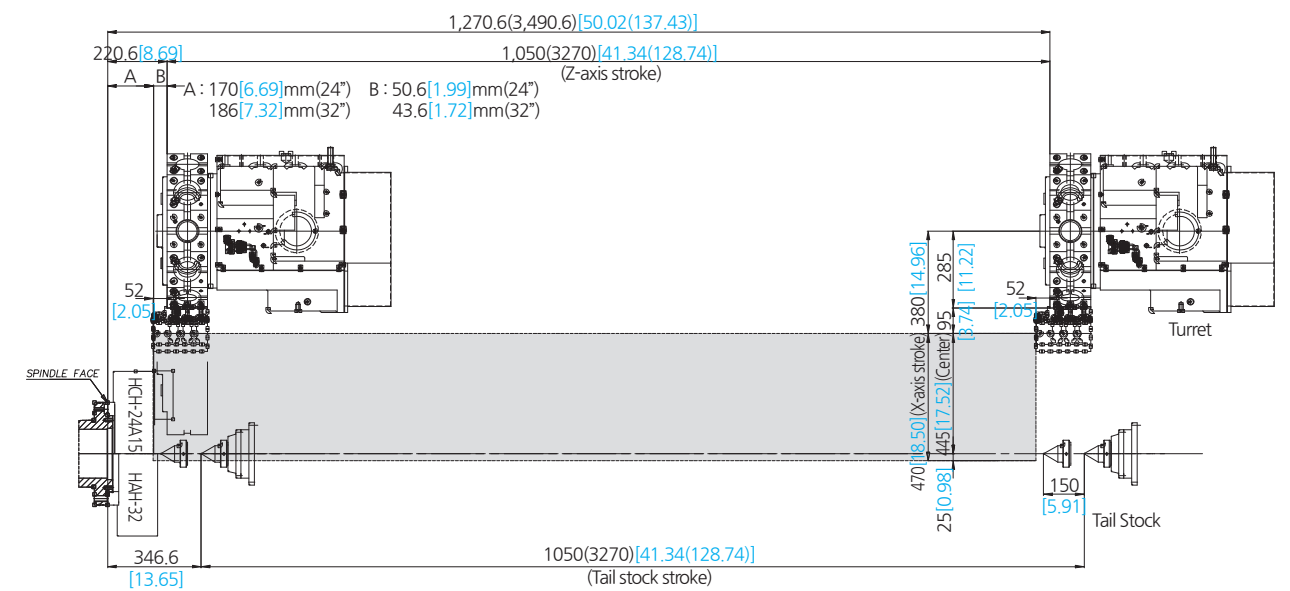

DL 70/70M

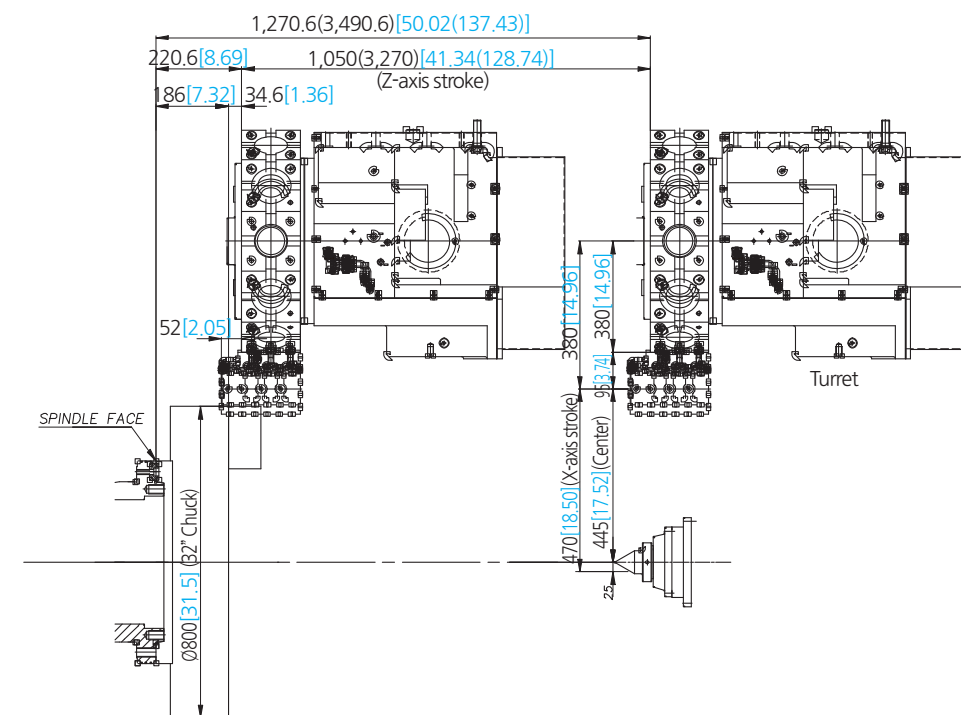

Machine lay-out

Unit : mm(inch)

DL 60L(M)

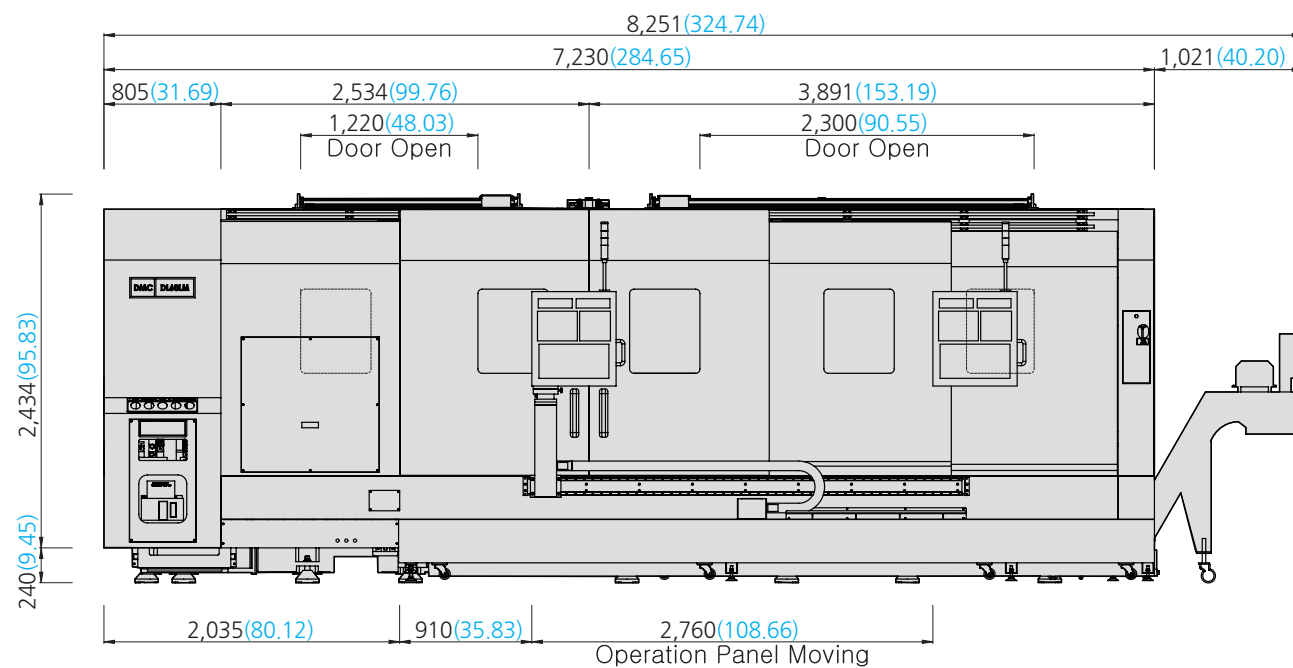

Front

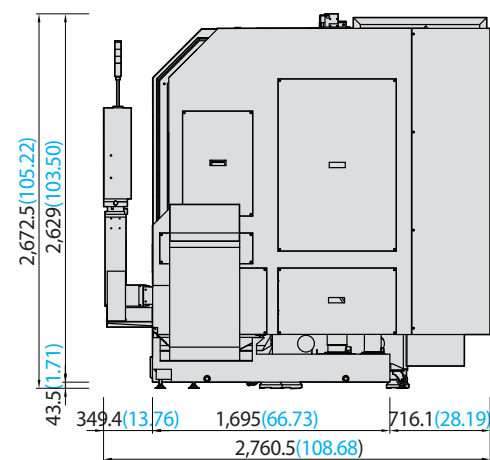

Side

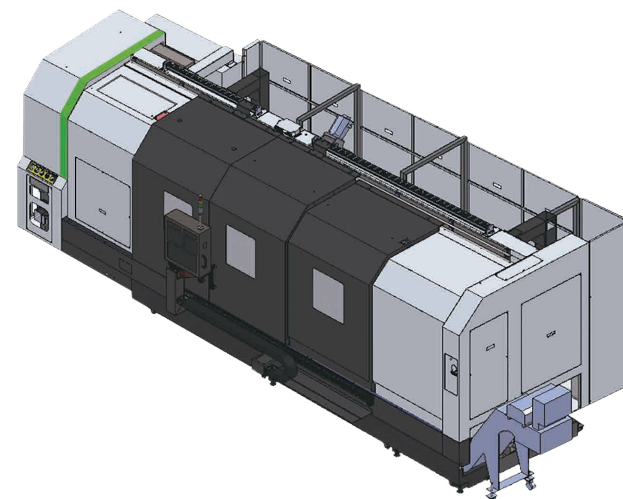

Perspective

Machine Specifications

Specifications		Unit	DL 60L[M]	
Capacity	Swing over Bed (Max.swing dia.)	mm(inch)	1,030(40.55)	
	Swing over Cross slide	mm(inch)	800(31.5)	
	Max. Turning Dia.	mm(inch)	900(35.43)	
	Max.Turning Length	mm(inch)	3,200(125.98)	
Main spindle	Max.Spindle Speed	rpm	1,400	
	Spindle Nose	-	A2-15	
	Spindle Bore diameter	mm(inch)	181(7.13)	
	Max. Spindle Torque	kgf·m(lbs·ft)	503(3,639)	
	Chuck Size	inch	24[32]	
Motor	Main Spindle Motor(Cont./30min)	kw(hp)	37/45(50/60)	
	X axis Servo Motor	kw(hp)	7(9.38)	
	Z axis Servo Motor	kw(hp)	6(8.04)	
	Mill Spindle Motor(Cont./30min)	kw(hp)	[M]:11(14.75)	
Travel	X axis travel	mm(inch)	470(18.50)	
	Z axis travel	mm(inch)	3,270(128.74)	
	Guideway Type(X/Z)	-	BOX Way	
	X axis rapid traverse rate	m/min(ipm)	12(472.44)	
	Z axis rapid traverse rate	m/min(ipm)	10(393.70)	
Turret	Turret Index Type	-	Servo	
	Max. No. of Tools	ea	12[BMT85]	
	Turning tool shank size	mm(inch)	□32(1.26)	
	Boring bar diameter	mm(inch)	80(3.15)	
	Turret Indexing Time(1st swivel)	sec	0.25	
Tailstock	Tailstock Quill diameter	mm(inch)	180(7.09)	
	Tailstock Quill stroke	mm(inch)	150(5.91)	
General	Machine Weight	kgf(lbs)	22,300(49,162.36)	
	Machine height	mm(inch)	2,685(105.71)	
	Floor space	Length	mm(inch)	7,437(292.80)
		Width	mm(inch)	2,750(108.27)
	Power capacity	kVA	71[81]	
	Controller	-	FOi- TF	

Machine Specifications

Specifications		Unit	DL 70[M]	
Capacity	Swing over Bed (Max.swing dia.)	mm(inch)	1,030(40.55)	
	Swing over Cross slide	mm(inch)	800(31.5)	
	Max. Turning Dia.	mm(inch)	900(35.43)	
	Max. Turning Length	mm(inch)	1,000(39.37)	
Main spindle	Max. Spindle Speed	rpm	750	
	Spindle Nose	-	A2-20	
	Spindle Bore diameter	mm(inch)	320(12.60)	
	Max. Spindle Torque	kgf·m (lbs·ft)	745(5,388)	
	Chuck Size	inch	DEPENDING ON USER	
Motor	Main Spindle Motor(Cont./30min)	kw(hp)	37/45(50/60)	
	X axis Servo Motor	kw(hp)	7(9.38)	
	Z axis Servo Motor	kw(hp)	6(8.04)	
	Mill Spindle Motor(Cont./30min)	kw(hp)	[M]:11(14.75)	
Travel	X axis travel	mm(inch)	470(18.50)	
	Z axis travel	mm(inch)	1,050(41.34)	
	Guideway Type(X/Z)	-	BOX Way	
	X axis rapid traverse rate	m/min(ipm)	12(472.44)	
	Z axis rapid traverse rate	m/min(ipm)	18(708.66)	
Turret	Turret Index Type	-	Servo	
	Max. No. of Tools	ea	12[BMT85]	
	Turning tool shank size	mm(inch)	□32(1.26)	
	Boring bar diameter	mm(inch)	80(3.15)	
	Turret Indexing Time(1st swivel)	sec	0.25	
Tailstock	Tailstock Quill diameter	mm(inch)	180(7.09)(OPT)	
	Tailstock Quill stroke	mm(inch)	150(5.91)(OPT)	
General	Machine Weight	kgf(lbs)	18,060(39,814.90)	
	Machine height	mm(inch)	2,685(105.71)	
	Floor space	Length	mm(inch)	5,237(206.18)
		Width	mm(inch)	2,750(108.27)
	Power capacity	kVA	71[81]	
	Controller	-	F0i- TF	

NC Specifications (FANUC FOi-TF)

○ : Standard, OPT. : Option, (!) : M type, (!!): 2SO type

	Item	Specification	0iTF
Controls	Controlled axes	Std. 2axes	X, Z, C (!)
	Simultaneously control axes expansion(Total)	0.001mm/0.0001"	3 axes (!)
Axis Functions	Least input increment		○
	Cs contouring control		○ (!)
	HRV2 Control		○
	Inch/metric conversion	G20/G21	○
	Increment system 1/10	0.0001mm/0.00001"	○
	Stored stroke 1	Overtravel control	○
	Stored stroke 2 and 3		○
	Mirror image		○
	Chamfering on/off		○
	Backlash compensation	Max. 255 pulses	○
Operation	Stored pitch error compensation		○
	Automatic operation(memory)		○
	MDI operation		○
	Buffer register		○
	Program restart		○
	Search function	Sequence NO. / Program NO. / Address	○
	DNC operation		○
	Reference position shift		-
	Manual handle feed rate	X1, X10, X100	○
	Manual pulse generator	1 unit	○
Interpolation	Manual handle interruption		○
	Linear interpolation	G01	○
	Circular interpolation	G02, G03	○
	Dwell	G04	○
	Polar coordination interpolation	G12.1, G13.1	○ (!)
	Cylindrical interpolation		○ (!)
	Thread cutting/Synchronous cutting		○
	Multiple threading		○
	Thread cutting retract		○
	1st, 2nd reference position return & check	G27, G28, G30	○
Feed functions	Variable lead thread cutting		○
	Continuous thread cutting		○
	Circular thread cutting		OPT.
	3rd and 4th reference point return		○
	polygon turning		OPT.
	Helical interpolation		OPT.
	Rapid traverse override	F0/25/50/100%	○
	Feedrate Override	0-200% (10% unit)	○
	Jog feed override	0-2000 mm/min	○
	Feed per minute	G98	○
Axullary & Spindle functions	Feed per revolution	G99	○
	Cutting feedrate clamp		○
	External deceleration		○
	Feed stop		-
	AI Comtour contr II ol I/II		OPT.
	Spindle speed override	0~150%	○
	Constant surface speed control	G96, G97	○
	1st Spindle orientation		○
	Rigid tapping		○
	Multi-spindle control		○ (!)
Programming functions	Auxiliary function	M8 digit	○
	Program/code	EIA/ISO	○
	Optional block skip	1 Piece	○
	Additional block skip	Total 9(Only NC function)	○
Programming functions	Maximum command dimension	± 99999.999mm(± 9999.9999 inch)	○
	Program file name	32 characters	○
	Sequence number	N8 digit	○
	Absolute / Incremental programming		○
	Decimal point input		○
	Work coordinate system selection	G52 ~ G59	○
	Direct drawing dimension programming		○
	G code system A/B/C		○
	G code system B/C(selectable)		○
	Chamfering / corner R		○
	Programmable data input	G10	○
	Sub program call	Nested holds	10
	Custom macro		○
	Simple canned cycles	G90, G92, G94	○
	Circular interpolation by R programming		○
Multi repetitive canned cycle	G70 ~ G76	○	
Multi repetitive canned cycle2		○	
Drilling canned cycle(G80 series)		○	
Tape format for FANUC series 10/11		○	
Manual guide oi		OPT.	
Tool functions	Tool number command(t-code function)	T4-digit	○
	Number of tool offsets		128 Pairs
	Tool offset	G43, G44, G49	○
	Tool nose radius compensation	G40 ~ G42	○
	Tool geometry / wear offset	Geometry & wear data	○
	Tool life management		○
	Tool offset value counter input		○
	Auto tool offset		○
	Direct input of tool offset value measured B		○
	Editing op. functions	Part program storage size	
No. of Registered programs			400 ea
Part program editing			○
Program protect			○
Background editing			○
Setting & display	Expanded part program editing	Copy, Move, Change of NC program	○
	Status display		○
	Program name display	31 characters	○
	Self diagnostic function		○
	Help function	Alarm & Operation display	○
	Running time / Parts number display	Auto running time & Parts No. display	○
	Load meter display	Spindle & Servo load display	○
	External message display		○
	Display of spindle speed and T-code at all screen		○
	Tool path graphic display		○
Data input & output	Servo setting screen		○
	Spindle setting screen		○
	Multi language display		○
	I/O interface	RS-232C/LAN Port	○
	Memory card input and output		○
Other functions	External key input		○
	External program input		○
	External work number search		○
	USB Memory	Input/Output	○
	Fast Data Server	Only 1 path, need option board	OPT
Other functions	MDI / DISPLAY unit		10.4"
	PMC system		○
	Ethernet function	Embedded ethernet function	○