

# T6 Single 1R

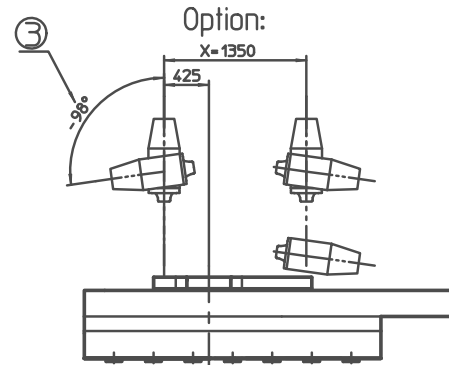
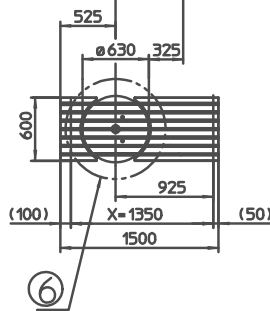
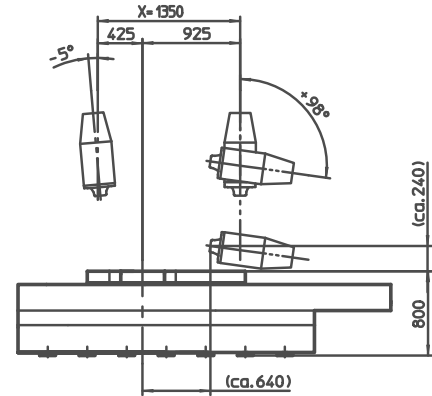
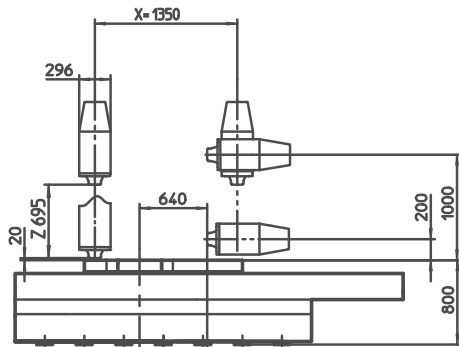
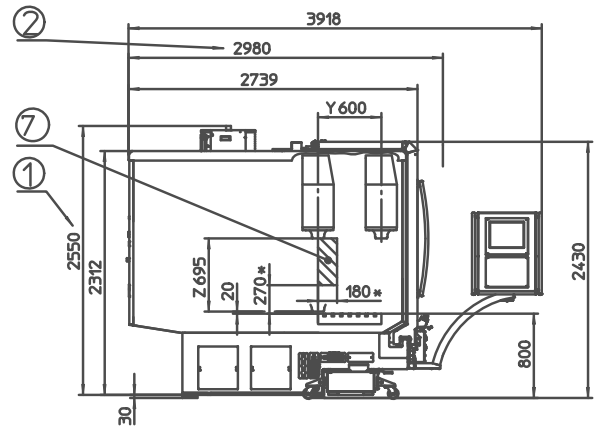
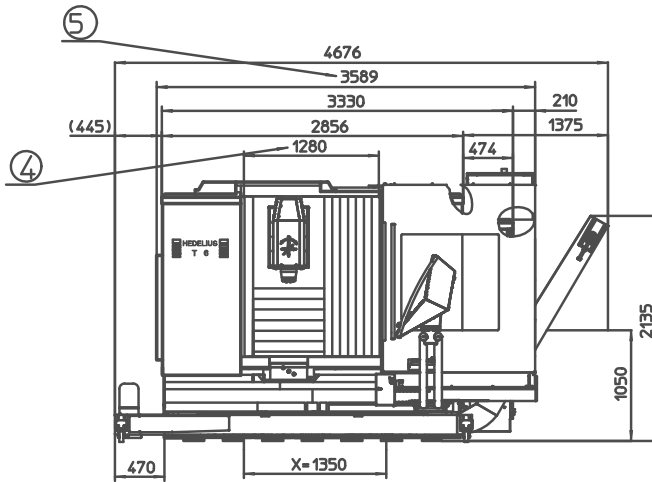

①	Liefer-/Transporthöhe: 2550 mm	Delivery/transportation height: 2550 mm	Livraison/Transport taille: 2550 mm	Altezza di spedizione/trasporto: 2550 mm	Levering / Transport hoogte: 2550 mm
②	Liefer-/Transportbreite: 2980 mm	Delivery/transportation width: 2980 mm	Livraison/Transport largeur: 2980 mm	Larghezza di spedizione/trasporto: 2980 mm	Levering / Transport breedte: 2980 mm
③	Option: Erweiterter Schwenk- bereich	Option: extended swivel range	Option: plage de pivotement prolongée	Opzione: raggio d'azione esteso	Optie: Uitgebreid zwenkbereik
④	Bedienöffnung bei geöffneter Tür	Service opening	Ouverture de manoeuvre avec portes ouvertes	Apertura di manovra con porta aperta	Opening van de operatie met geopende deur
⑤	Bei geöffneter Tür	With opened door	Avec des portes ouvertes	Con porte aperte	Met geopende deur
⑥	Störkreisdurchmesser: 950 mm	Rotation circle diameter: 950 mm	Diamètre du cercle perturbateur: 950 mm	Diametro di interferenza: 950 mm	Swivel diameter: 950 mm
⑦	Werkzeugwechselbereich (*Werte bei max. Werkzeugab- messung): Diesen Bereich für den Werkzeugwechsel freihalten oder Fahrständer in einen sicheren Bereich fahren, in dem keine Kollisionsgefahr besteht.	Tool change area (*values at maximum tool size): Keep this area free for tool changes or bring the traveling column in a secure area without risk of collision.	Zone de changement d'outil (*Les valeurs à maximale dimension de l'outil): Garder cette zone pour le changement d'outils ou apporter la colonne dans une zone de sécurité sans risque de collision.	Zone per cambio utensile (*valori in formato massimo utensile): Mantenere questa zona libero per il cambio utensile o portare il colonna in una zona sicura, senza pericolo di collisione.	Zone voor gereedschapswissel (*waarden bij max. gereedschap grootte): Houd dit gebied vrij voor de gereedschapswissel of breng kolom in een beveiligde ruimte waarin geen gevaar voor een botsing.