

F7 Single

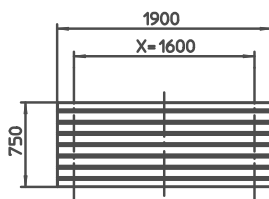
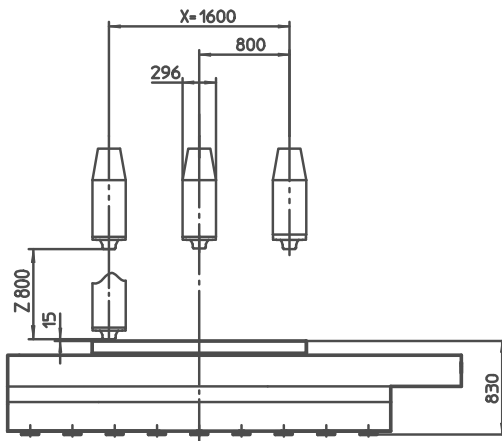
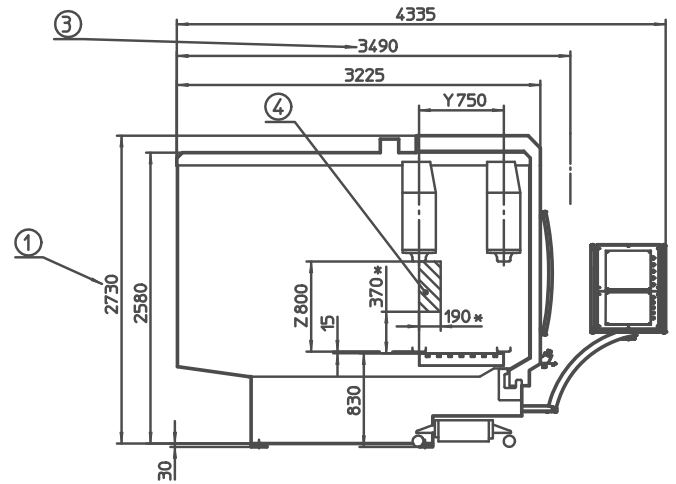
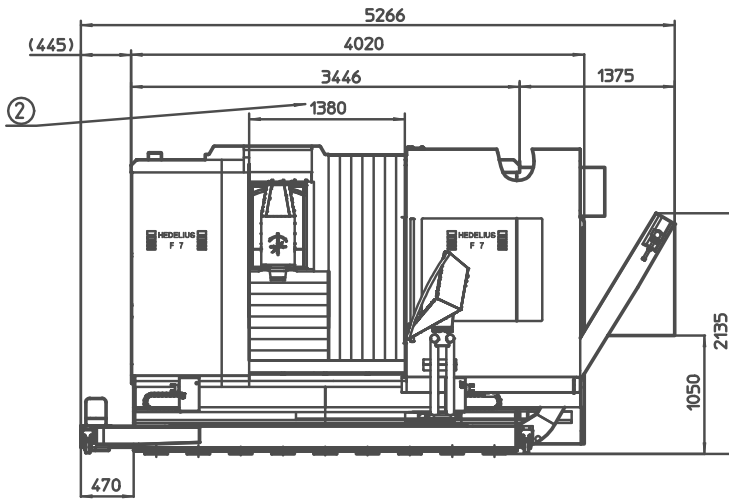

①	Liefer-/Transporthöhe: 2730 mm	Delivery/transportation height: 2730 mm	Livraison/Transport taille: 2730 mm	Altezza di spedizione/trasporto: 2730 mm	Levering / Transport hoogte: 2730 mm
②	Bedienöffnung bei geöffneter Tür	Service opening	Ouverture de manoeuvre avec portes ouvertes	Apertura di manovra con porta aperta	Opening van de operatie met geopende deur
③	Liefer-/Transportbreite: 3490 mm	Delivery/transportation width: 3490 mm	Livraison/Transport largeur: 3490 mm	Altezza di spedizione/trasporto: 3490 mm	Levering / Transport breedte: 3490 mm
④	Werkzeugwechselbereich (*Werte bei max. Werkzeugab- messung): Diesen Bereich für den Werkzeugwechsel freihalten oder Fahrständer in einen sicheren Bereich fahren, in dem keine Kollisionsgefahr besteht.	Tool change area (*values at maxi- mum tool size): Keep this area free for tool changes or bring the traveling column in a secure area without risk of collision.	Zone de changement d'outil (*Les valeurs à maximale dimension de l'outil): Garder cette zone pour le changement d'outils ou apporter la colonne dans une zone de sécu- rité sans risque de collision.	Zone per cambio utensile (*valori in formato massimo utensile): Mantenere questa zona libero per il cambio utensile o portare il colonna in una zona sicura, senza pericolo di collisione.	Zone voor gereedschapswissel (*waarden bij max. gereedschap grootte): Houd dit gebied vrij voor de gereedschapswissel of breng kolom in een beveiligde ruimte waarin geen gevaar voor een botsing.